

Owners & Installation

Manual

LISTINGS AND CODE APPROVALS

These gas appliances have been tested in accordance with AG 103, NZS 5262 and have been certified by the Australian Gas Association for installation and operation as described in these Installation and Operating Instructions.

Your unit should be serviced annually by an authorised service person.

Masport®

New York / Ultimate

(Australia)

(New Zealand)

Model: I43-NG Natural Gas
I43-LP Propane



PLEASE KEEP THESE INSTRUCTIONS FOR FUTURE REFERENCE

WARNING:

Improper installation, adjustment, alteration, service or maintenance can cause injury or property damage. Refer to this manual. For assistance or additional information consult an authorised installer, service agency or the gas supplier.

FOR YOUR SAFETY

Do not store or use gasoline or other flammable vapours and liquids in the vicinity of this or any other appliance.

Installation and service must be performed by an authorised installer, service agency or the gas supplier.

FOR YOUR SAFETY

What to do if you smell gas:

- Do not try to light any appliance
- Do not touch any electrical switch: do not use any phone in your building.
- Immediately call your gas supplier from a neighbour's phone. Follow the gas supplier's instructions.
- If you cannot reach your gas supplier, call the fire department.

Head Office - Australia
54 Boundary Rd. Braeside
P.O. Box 553
Mordialloc 3195
Ph. (03) 9586-7777
Fax. (03) 9586-2980

Head Office - New Zealand
1-37 Mt Wellington Hwy. Panmure,
P.O. Box 14349
Auckland 6.
Ph. (9) 570-9009
Fax. (9) 527-1294

MASPORT GAS INBUILT FIREPLACE

TO THE NEW OWNER

Congratulations! You are the owner of a state-of-the-art Gas Inbuilt Fireplace by MASPORT. The Masport Gas Fireplace Series of hand crafted appliances has been designed to provide you with all the warmth and charm of a fireplace, at the flick of a switch. The models I43-NG and I43-LP of this series have been approved by Warnock Hersey for both safety and efficiency. As it also bears our own mark, it promises to provide you with economy, comfort, and security for many trouble free years to follow. Please take a moment now to acquaint yourself with these instructions and the many features of your Masport Fireplace.

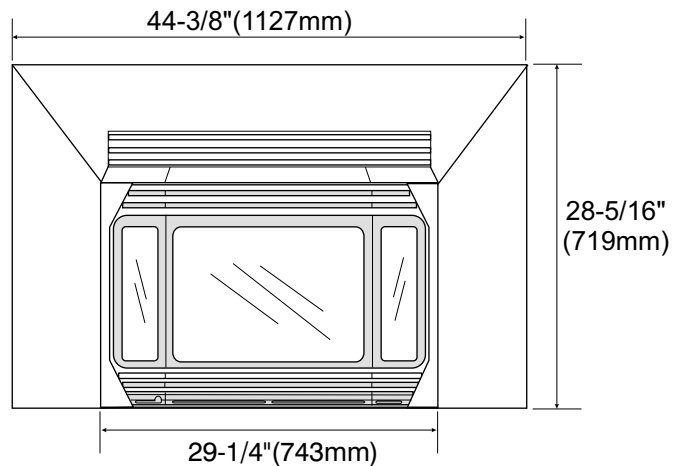
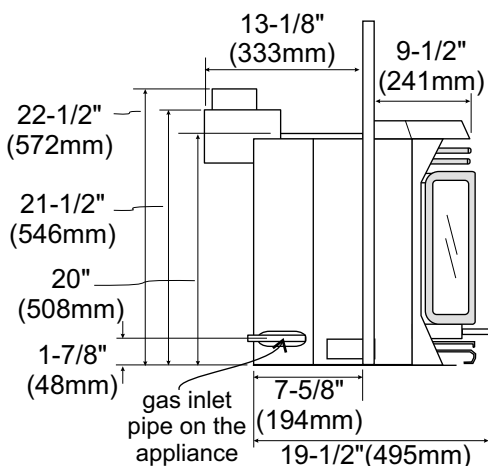
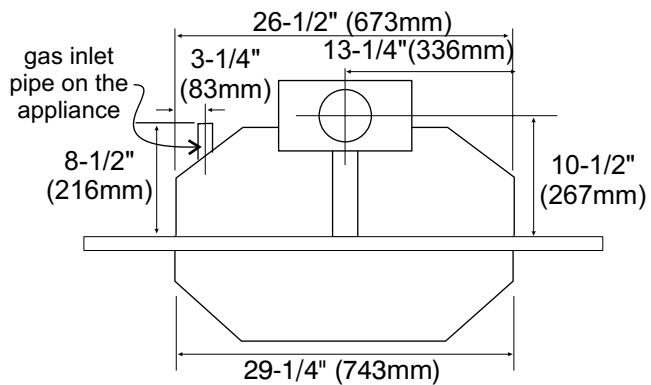

Note: Oversize faceplate 1124mm x 791mm
Extra Oversize Faceplate 1276mm x 892mm

TABLE OF CONTENTS

MASPORT GAS INBUILT FIREPLACE

	Page		Page
SAFETY LABEL		OPERATING INSTRUCTIONS	
Safety Labels	4	Operating Instructions.....	16
INSTALLATION REQUIREMENTS		Lighting Procedure	16
For your safety	5	Shutdown Procedure	16
Gas Pipe Testing	5	Copy of Lighting Plate Instructions	17
Specifications	5	First Fire	18
Before You Start	5	Automatic Convection Fan Operation	18
Installation Checklist	6	Normal Operating Sounds of	
Materials Required	6	Gas Appliances	18
Clearances		MAINTENANCE	
-Minimum Fireplace Clearances	6	Maintenance	19
-Clearances to Combustibles	7	Log Replacement.....	20
-Clearances to Combustible Mantels	7	Gold Plated Doors	20
INSTALLATION INSTRUCTIONS		Door Gasket and Glass Gasket	20
System Data Table	8	Latch Adjustment	20
Gas Connection	8	Glass Replacement	20
Draft Diverter Connection	9	Fan Maintenance	21
Flueing	9	Troubleshooting Guide	22
Combustion & Ventilation Air	10	Parts List	23
Gas Pressure Test	10	WARRANTY	
Aeration System	10	Warranty	27
Test For Flue Spillage	11		
Faceplate & Trim Installation	12		
Brick Panels	13		
Log Installation	13		
Door Installation & Door Latches	14		
Optional Wall Thermostat Installation	14		
Optional Remote Control Installation	15		
Final Check	15		
Wiring Diagram	15		

DATA BADGE

This is a copy of the label that accompanies each Masport Gas Inbuilt. We have printed a copy of the contents here for your review. The safety label is located on the right side door panel.

DATA BADGE NOTE: Masport units are constantly being improved. Check the label on the unit and if there is a difference, the label on the unit is the correct one.

Masport

Model	<input type="radio"/>	<input type="radio"/>	<input type="radio"/>	<input type="radio"/>	<input type="radio"/>	<input type="radio"/>	
Gas Type	Nat	Prop	Nat	Prop	Nat	Prop	
Model	P36-NG	P36-LP	I31-2NG	I31-2LP	I43-NG	I43-LP	
Gas Consumption	33mj.	31mj.	31mj.	31mj.	40mj.	39mj.	
Manifold Pressure	1.0kPa	2.7kPa	.9kPa	2.59kPa	.85kPa	2.55kPa	
Injector Size	-Front:	1x#37	1x#52	1x#37	1x#52	1x#31	1x#56
		2.65mm	1.6mm	2.65mm	1.6mm	3.0mm	1.15mm
	- Rear	NA	NA	NA	NA	NA	1x#54
AGA Approval number to Code AG103	5815	5815	5498	5498	5810	5810	1.4mm

Electrical Conforms to AS3100 240V 50Hz 1.0 amp Max.

908-063 02/01

Distributed by:

Masport Pty. Ltd.
Industrial Drive
Braeside, Victoria. 3195

Masport Ltd.
1-37 Mt. Wellington H/Way
Auckland 6
New Zealand

To be installed in a non-combustible fireplace by an authorised person in accordance with installation instructions provided with the appliance. See P36 Zero Clearance, and I31 & I43 Zero Clearance Box instructions

Serial Number

DO NOT OPERATE THIS APPLIANCE BEFORE READING THE INSTRUCTIONS BOOKLET.

DO NOT PLACE ARTICLES ON OR AGAINST THIS APPLIANCE

DO NOT STORE CHEMICALS OR FLAMMABLE MATERIALS, OR SPRAY AEROSOLS NEAR THIS APPLIANCE.

DO NOT OPERATE WITH PANELS, COVERS OR GUARDS REMOVED FROM THIS APPLIANCE.

DO NOT ENCLOSE THIS APPLIANCE.

908-602

THE GUARD IS FITTED TO THIS APPLIANCE TO REDUCE THE RISK OR FIRE OR INJURY FROM BURNS AND NO PART OF IT SHOULD BE PERMANENTLY REMOVED.

FOR PROTECTION OF YOUNG CHILDREN OR THE INFIRM, A SECONDARY GUARD IS REQUIRED.

(Australia Only)

INSTALLATION REQUIREMENTS

IMPORTANT: SAVE THESE INSTRUCTIONS

The Masport I43 Gas Fireplace must be installed in accordance with these instructions. Carefully read all the instructions in this manual first. Consult the "authority having jurisdiction" to determine the need for a permit prior to starting the installation.

Note: Failure to follow these instructions could cause a malfunction of the heater which could result in death, serious bodily injury, and/or property damage. Failure to follow these instructions may also void your fire insurance and/or warranty.

FOR YOUR SAFETY

This appliance requires air for proper combustion. Always provide adequate combustion and ventilation air. Follow instructions and information in the current AG 601 or local codes.

GAS PIPE TESTING

The appliance must be isolated from the gas supply piping system by closing its individual manual shutoff valve during any pressure testing of the gas supply piping system at test pressures equal to or less than 1/2 psig. (3.45 kPa).

SPECIFICATIONS

Fuel:	Natural Gas or Propane
Electrical:	240 volt. system
Fan:	2 speed, 75/125 CFM
Log Sets:	Ceramic fibre, 3 per set

BEFORE YOU START

Installation is to be carried out ONLY by an authorised person.

- 1) The appliance shall be installed in accordance with the manufacturer's installation instructions, local gas fitting regulations, municipal building codes, water supply regulations, electrical wiring regulations, with AG 601 (AGA gas installation code) NZS 5261 (New Zealand)
- 2) **Installation and repair should be done ONLY by an authorised person.**
- 3) The appliance should be inspected before use and at least annually by an authorised service person. More frequent cleaning may be required due to excessive lint from carpeting, bedding material, etc. It is imperative that control compartments, burners and circulating air passageways of the appliance be kept clean and free from excessive lint from carpeting.
- 4) See general construction and assembly instructions. This appliance may only be installed in a flued noncombustible fireplace. The appliance and flue should be enclosed when installed or passing through a living area, where children may come in contact with it.
- 5) Always connect this fireplace to a flue to the outside of the building envelope. Never flue to another room. Make sure that the flue is properly sized and is of adequate height to provide the proper draft.
- 6) Inspect the flue system annually for blockage and any signs of deterioration.
- 7) Any safety glass removed for servicing must be replaced prior to operating the appliance.
- 8) To prevent injury, do not allow anyone who is unfamiliar with the operation to use the fireplace.

INSTALLATION REQUIREMENTS

INSTALLATION CHECKLIST

The Masport Gas Inbuilt is installed as listed below.

- 1) Unit Location - check Clearances to Combustibles on page 7.
- 2) Make the gas connections and electrical connection for fan and flue spill switch. See page 8.
- 3) Install the flue or liner to the sliding draft diverter. See page 9.
- 4) Install Flueing, page 9. Slide the unit into the fireplace and level. Attach draft diverter to the inbuilt.
- 5) Test gas pressure, page 10. Check aeration, page 10.
- 6) Test for flue spillage, page 11.
- 7) Assemble and install the faceplate and trim. See page 12.
- 8) Install the optional brick panels. See page 13.
- 9) Install the 3 logs and embers. See page 13.
- 10) Install Doors. See page 14.
- 11) Install Optional Remote Control and Optional Wall Thermostat, pages 14 and 15.
- 12) Explain controls to the homeowner.
- 13) **Final check:** Before leaving this unit with the customer, the installer must ensure that the appliance is firing correctly. This includes:
 - a) Clocking the appliance to ensure the correct firing rate.
 - b) Adjusting the primary air, if required, to ensure that the flame does not carbon. See page 10.
 - c) Ensuring that the appliance is flueing correctly. See page 11.

MATERIALS REQUIRED

No electrical power supply is required for the gas control to operate. A 240 Volt AC power cord is hooked up to the fan switch and fan. Plug 3 wire cord into a suitable receptacle. **Do not cut the ground terminal off under any circumstances.**

When connected with 240 volts, the appliance must be electrically grounded in accordance with local codes, or in the absence of local codes with the current version of National Code AS 3100.

Note: This unit is equipped with a heat sensor thermo-disc which will prevent the fan from operating until the unit reaches the correct temperature.

CLEARANCES

Minimum Fireplace Clearances

The minimum fireplace clearances for the Masport gas inbuilt fireplace are shown in the following diagrams:

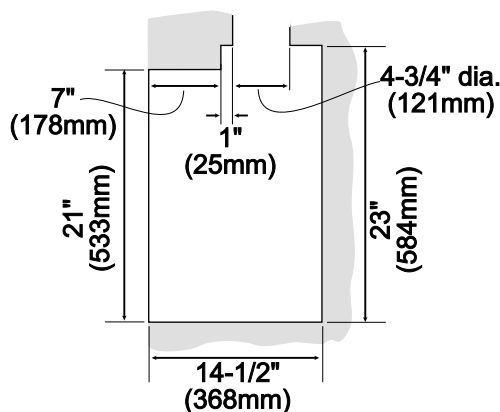
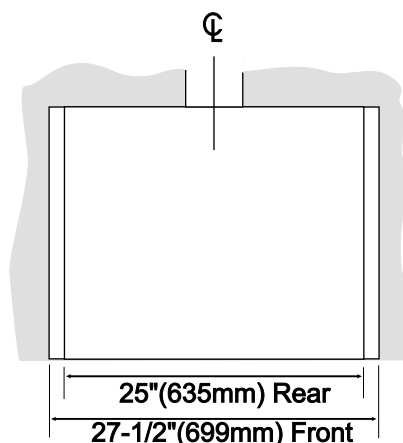
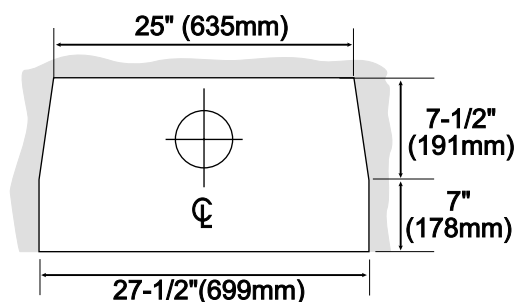

INSTALLATION REQUIREMENTS

Clearances to Combustibles

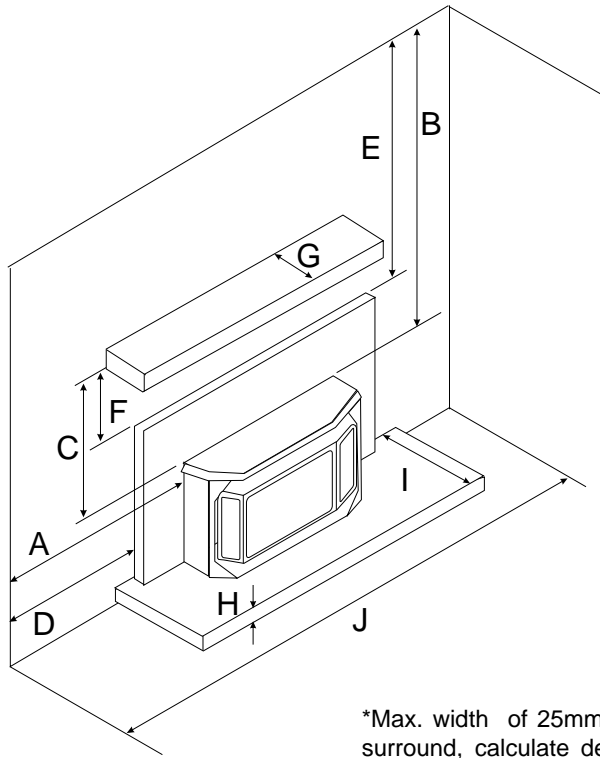

Sides	From Unit	A	7.5" / 190 mm
Ceiling	B	35" / 890 mm	
Mantel	C(My)	11" / 280 mm	
From Surround			
Sides	D	2" / 50 mm	
Ceiling	E	25.5" / 650 mm	
Mantel	F	3" / 75 mm	
Min. Alcove Width	J	48" / 1120 mm	
Mantel Depth	G(Mx)	7.5" / 190 mm	
Facing (Mantel Leg)			
Side*	K	1" / 25 mm	
Top	L	1" / 25 mm	

*Max. width of 25mm at 25mm from surround, calculate depth at 45° as shown in the diagram.

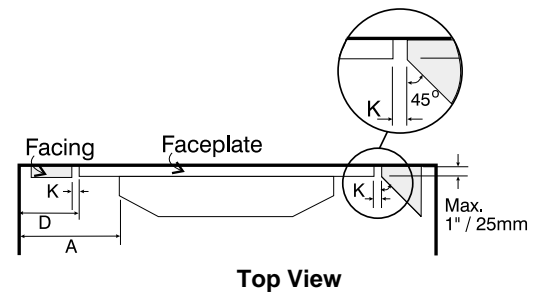

Mantle Clearances (mm)									
Width (Mx)	140	152	165	178	190	203	216	229	241
Clearance (My)	279	289	298	311	317	321	324	327	330

Non-combustible Hearth Extension (mm)										
Height (Hy)	0	16	32	48	60	70	79	89	95	101
Depth (Hx)	635	610	584	559	533	508	483	457	432	406

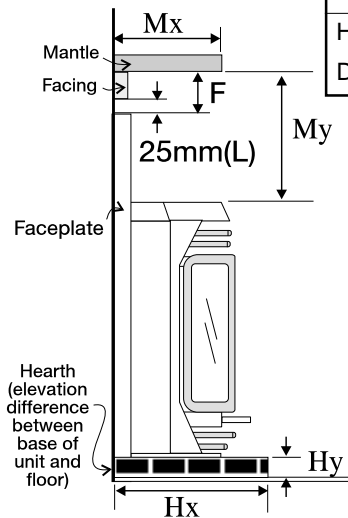

Note: A non-combustible mantel may be installed at a lower height if the framing is made of metal studs covered with a non-combustible board.

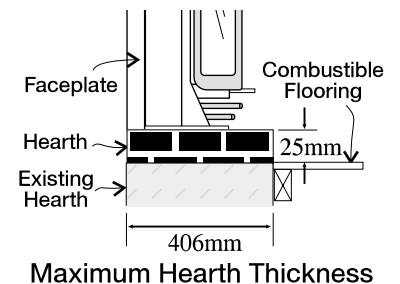
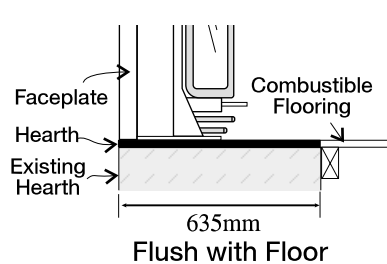

INSTALLATION INSTRUCTIONS

System Data For 0 to 610 metres altitude*		
Burner Inlet Orifice Sizes:		
	Natural Gas	Propane
Rear Burner	n/a	#54(1.4mm)
Front Burner	#31(3.0mm)	#56(1.15mm)
Input Rating		
- Natural Gas		40 mj
- Propane		39 mj
Supply Pressure:		
Natural Gas	min.	1.13 kPa
Propane	min.	2.75 kPa
Manifold Pressure		
Natural Gas		.85 kPa
Propane		2.55 kPa

- 1) If the appliance is to be installed into an existing chimney system, thoroughly clean the masonry fireplace and have the chimney swept.
- 2) The gas connection is a 1/2" BSP male pipe on the rear left side of the unit. The gas line can be rigid pipe or to make installation easier use a listed flexible connector and manual shut-off valve if allowed by local building codes. A 1/2" gas supply pipe must be brought near this inlet hole.
- 3) Locate the center point where the flue will pass through the chimney above the appliance. Move the appliance into the exact location where it is to be installed. Ensure that the Inbuilt is level.
- 4) The gas control valve is provided with two "IN" and "OUT" pressure taps, and are easily accessible for a test gauge connection (see diagram on page 10).
- 5) Once the gas has been connected ensure that the pilot valve is in line with burner.

GAS CONNECTION

For minimum and maximum supply pressure see the System Data table on page 8.

Note: Prior to any pressure testing of the gas supply piping system that exceeds test pressures of 1/2 psig (3.45 kPa), this appliance and its individual shut-off valve must be disconnected from the piping system. If test pressures equal to or less than 1/2 psig (3.45 kPa) are used then this appliance must be isolated from the piping system by closing its individual manual shut-off valve during the testing.

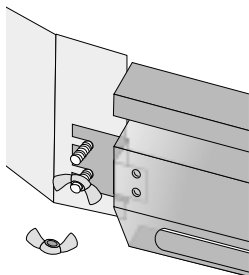

Valve Access: Loosen and remove the wingnuts on the both sides of the bottom louver and then remove the louver.

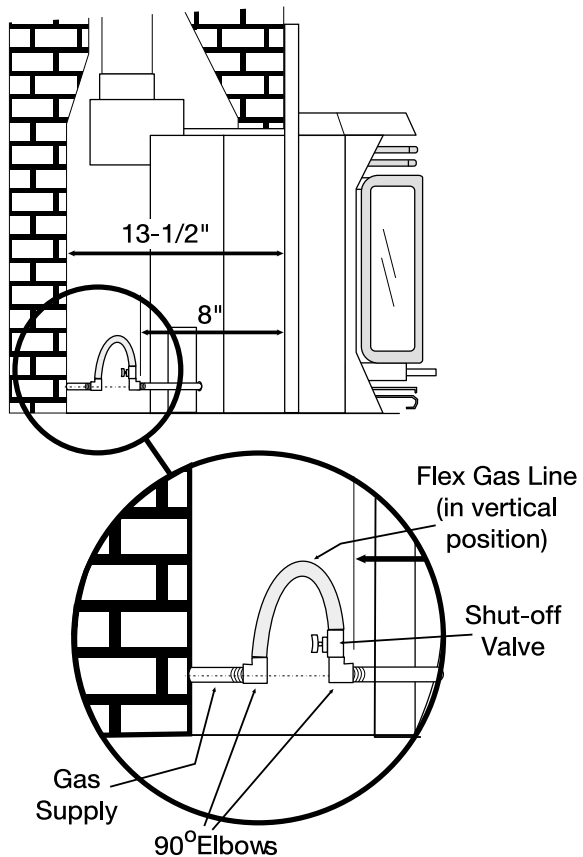

GAS CONNECTION WARNING:

Only persons licensed to work with gas piping may make the necessary gas connections to this appliance.

CAUTION: If the door is removed or opened for servicing, it must be replaced and closed prior to operating the appliance. The glass must be fixed in the door when operating.

INSTALLATION REQUIREMENTS

DRAFT DIVERTER CONNECTION

- 1) Attach the flue to the flue collar on the detachable draft diverter. The flue collar of the appliance will fit inside a standard 100mm flue and may be fastened directly to the flue by sheet metal screw.

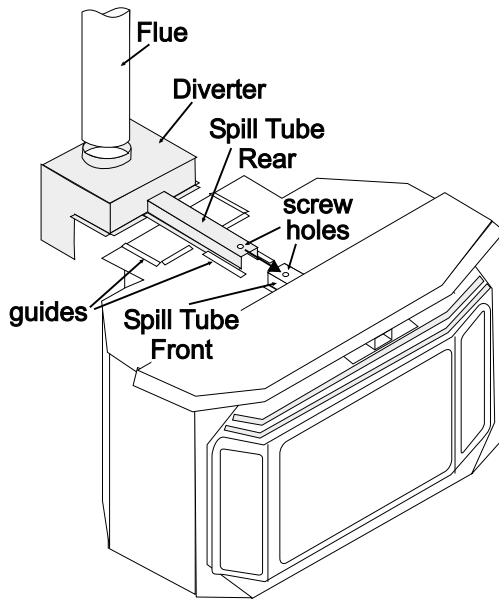

- 2) Before pushing the appliance into position inside the fireplace, align the draft diverter with the guides on the inbuilt top and push forward. While pushing the unit back into place keep pulling the draft diverter forward until the screw hole in the spill tube-rear aligns with the screw hole in the spill tube-front. (If screw holes do not line up then draft diverter is not positioned correctly.) Secure the two spill tubes with a screw.

Note: Final gas connection should be after unit is in place to avoid damage to line when pushing the unit into position.

FLUEING

THE APPLIANCE MUST NOT BE CONNECTED TO A CHIMNEY FLUE SERVING A SEPARATE SOLID FUEL BURNING APPLIANCE.

This appliance is designed to attach to a 100mm diameter flue or approved aluminum flex liner running the full length of the chimney. A minimum flue height of 3.6 m is recommended. B-Vent must be supported by a flue support - supplied by flue manufacturer. There must be at least 0.9 m of chimney above the roof level.

Stack the pipe onto your finish support to a minimum height of 0.9m above the roof penetration, or 0.6m above any point within 3m measured horizontally. B-Vent chimneys require a 25mm clearance to combustibles.

The Masport Inbuilt incorporates its own internal draft diverter, so no additional external draft diverter is required. Periodically check that the flue is unrestricted and an adequate draft is present when the unit is in operation. (See page 11 for spillage test.)

Before installing flue system ensure that the damper plate is locked into the open position and secure to prevent the damper plate from falling down and crushing the liner.

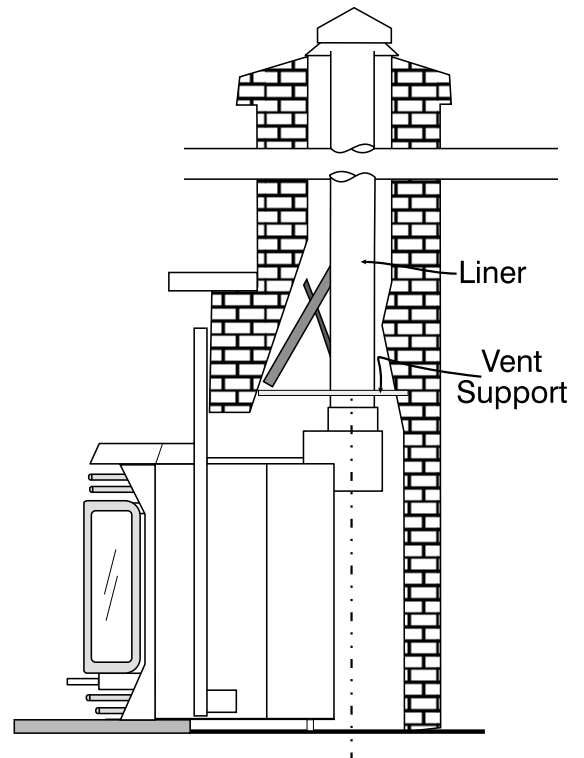

INSTALLATION INSTRUCTIONS

COMBUSTION & VENTILATION AIR

WARNING: This appliance needs fresh air for safe operation and must be installed with provisions for adequate combustion and ventilation air available to the room in which it is to be operating.

This appliance installation must conform with local codes or in the absence of local codes, with AG 601 or NZS 5261.

Air for combustion is drawn in through the front of the unit, therefore, the front of the unit must be kept clear of any obstructions.

GAS PRESSURE TEST

The manifold pressure is controlled by a regulator built into the gas control, and should be checked at the pressure test point.

Note: To properly check gas pressure, both inlet and manifold pressures should be checked using the valve pressure ports on the valve.

- 1) Make sure the valve is in the off position.

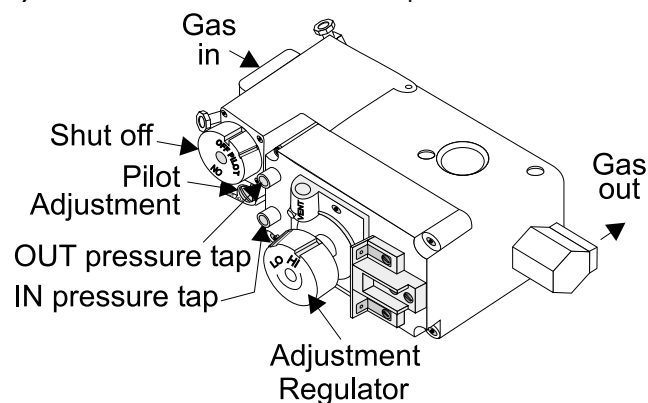

- 2) Loosen the screw at the outlet pressure test point, turn captured screw counterclockwise 2 or 3 turns and then placing tubing to gauge over test point.
- 3) Attach tubing to a manometer using a 8mm I.D. hose.
- 4) Light the pilot and turn the valve to "ON" position.
- 5) The pressure check should be carried out with the unit burning and the setting should be within the limits specified on the safety label.
- 6) When finished reading the manometer, turn off the gas valve, disconnect the hose and tighten the screw (clockwise) with a 3mm wide screwdriver closing torque: 9 in. lbs.

Note: Use the same manner to check the inlet pressure.

AERATION SYSTEM

The burner aeration is factory set but may need adjusting due to either the local gas supply, air supply or altitude.

Natural Gas: 8mm open
Propane: Fully open (rear) and fully open (front)

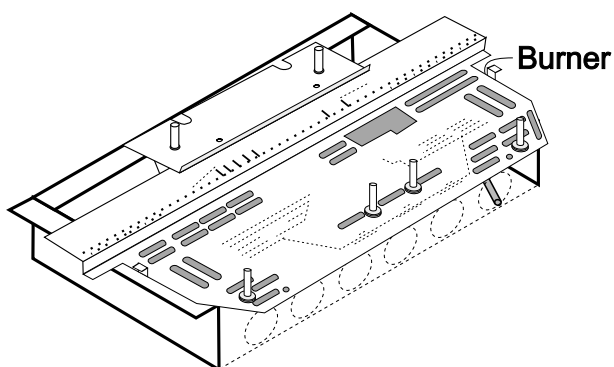
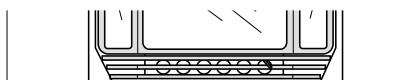

An aeration adjustment rod is attached to the air shutter on each burner. The rod is used to adjust the aeration on the burner without having to take the appliance apart. This adjustment is performed by an authorised installer. The factory setting should be sufficient for most installations.

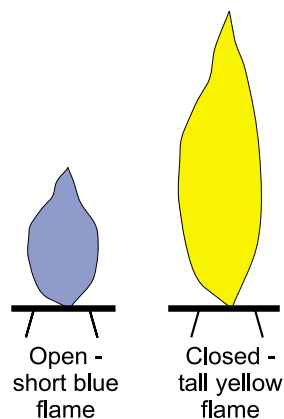

Note: Any damage due to carboning resulting from improperly setting the aeration controls is NOT covered under warranty.

INSTALLATION INSTRUCTIONS

TEST FOR FLUE SPILLAGE

A "spillage" test must be made before the installed unit is left with the customer. Follow the procedure below:

- 1) Start all exhaust fans in the home and then close all doors and windows in the room.
- 2) Light the unit and set controls to maximum. Turn fan off.
- 3) After five minutes, test that there is a "pull" on the flue by placing a smoke match, cigarette or similar device which gives off smoke, in front of the spill tube. To ensure a valid test, place a scrap piece of sheet metal (or other non-combustible material) between the spill tube and the upper louvre, this will prevent the natural convection of the unit from interfering with the test. See diagrams

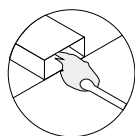

normal draft



downdraft or blocked flue

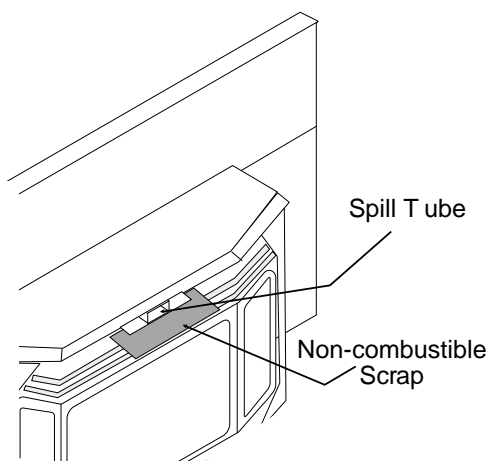

below.

The smoke should be drawn into the spill tube, if it does not, leave the unit for a further five minutes and retest as above. If the smoke is still not drawn into the spill tube, turn the unit off and check for the cause of the lack of draft. If necessary, rectify.

For wind turbulent sites, a wind cap may remedy the problem.

Note: *The thermally activated safety switch will sense the change in temperature and shut down the gas valve in the event of a severe downdraft of air or a blocked or disconnected flue. The switch acts as a safety shut-off to prevent a build up of carbon monoxide. If the flue is blocked or has no "draw", the switch will automatically shut off the supply of gas within 5 - 10 minutes. Tampering with the switch can result in carbon monoxide (CO) poison-*

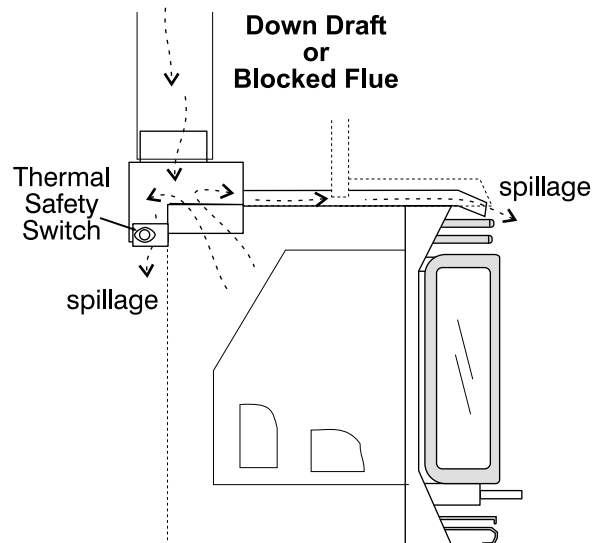

ing and possible death.

If the heater turns off because of lack of draft during the spillage test, check for the cause and if necessary, rectify.

The thermally actuated safety switch will automatically reset after it has reduced in temperature. The switch will continue to cycle until the draft problem is corrected. DO NOT BYPASS OR DISCONNECT THIS SWITCH.

INSTALLATION INSTRUCTIONS

FACEPLATE & TRIM INSTALLATION

Hint: Before doing the faceplate installation, leave the inbuilt out approximately 4" so wires may be hooked up easier.

- 1) Lay the faceplate panels flat, face down on something soft so they don't scratch.
- 2) Take the top faceplate and align the holes in it with the holes in the side panels. Attach, using the screws provided. See diagram 1.

Note: The holes in the top panel are slightly larger than the holes in the side panel to facilitate easier installation.

Hint: Don't tighten the screws down completely at this point, first do a trial fit to the unit. Make any necessary adjustments and when it fits properly then tighten down the screws.

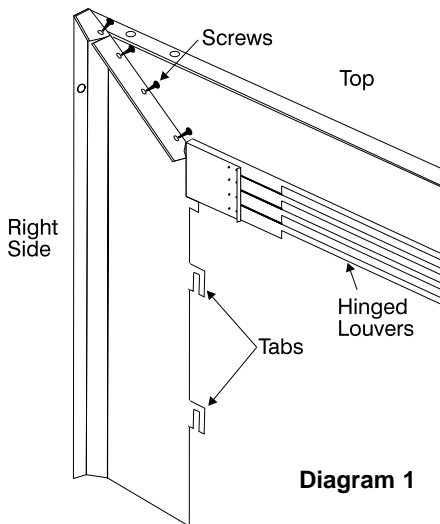

Diagram 1

- 3) Using the trim clips provided, join the left side gold trim (the one with the ON/OFF switch and FAN switch) to the top gold trim. See diagram 2. Repeat this step for right side.

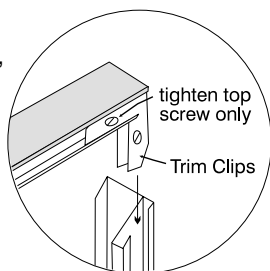
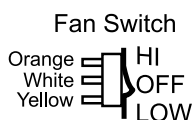

Diagram 2

- 4) Place the trim on the assembled faceplate panels, aligning the wires from the switches with the notch in the left side faceplate panel.



- 5) **FAN switch wires:** Hookup the 3 Fan Switch wires to the fan switch on the left side trim.
- 6) **Burner ON/OFF wires:** Hookup the 2 Burner ON/OFF wires to the Burner switch on the left side trim. Diagram 3.

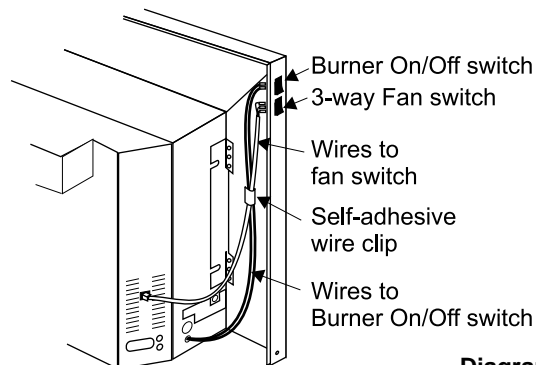

Diagram 3

WARNING: The 3 wires are to the Fan and the 2 wires are to the Burner ON/OFF switch. DO NOT connect to the wrong switch.

- 7) The power cord should be run behind the faceplate panel.
- 8) Push the logo plate into the two holes in the bottom left corner of the left side faceplate panel.
- 9) Secure the gold trim to the faceplate by drilling a 1/8" hole through into the faceplate side flange, using the hole in the trim as a guide. Now fasten with the two brass plated screws provided.

- 10) Lift the assembled faceplate up and over the top of the inbuilt and then lower it down so the faceplate tabs are in line with the faceplate brackets. See diagram 4. Once everything is properly lined up you can tighten the 4 screws on the faceplate brackets. See diagram 5.

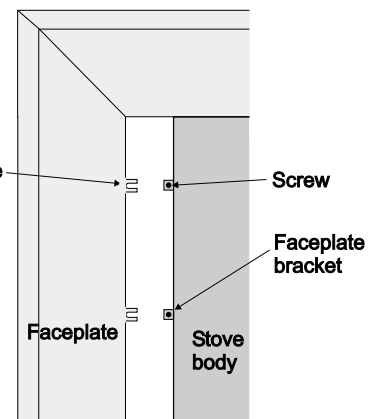

Diagram 4

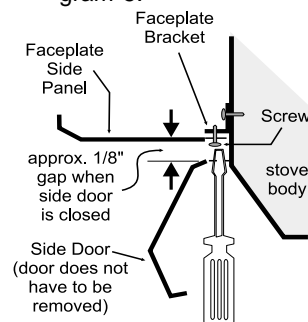

Diagram 5

Note: If you are making custom faceplates, you must use the faceplate louvers. Failure to do so will void the certification on your unit. The faceplate louvers can be purchased separately, part #: 610-909.

INSTALLATION INSTRUCTIONS

BRICK PANEL INSTALLATION

- 1) Unwrap the brick pattern panels from the protective wrapping.
- 2) Open the door and position the side brick panels into place from the front of the firebox. There are two tabs to the panels in place, one on each side. Carefully bend the tabs down with a screwdriver until panels are held securely in place.

Note: Use caution when putting the side panels in as they can easily be scratched by the hard component parts.

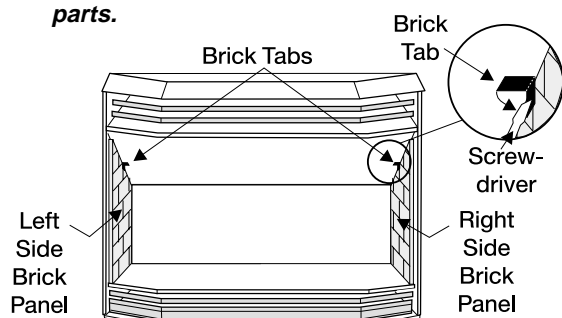

LOG INSTALLATION

WARNING: Dangerous operating conditions may occur if these logs are not positioned in their approved locations. Read the instructions below carefully and refer to the diagrams. If logs are broken do not use the unit until they are replaced. Broken logs can interfere with the pilot and burner operation.

The gas log kit contains the following:

- a) Front Right Log - Part # 902-192
 - b) Front Left Log - Part # 902-193
 - c) Rear log - Part # 902-194
 - d) Embers - Part # 902-151 (1 bag)
(Part # 650-933 for the set of three logs)
- 1) Remove the logs from the box and carefully unwrap them. The logs are fragile, handle with care - **DO NOT FORCE** into position.
 - 2) Place the rear log, carefully sliding it down onto the pins, with the flat side of the log facing the back of the unit. See diagram 1.
 - 3) Place the left front log, carefully sliding it down onto the left pins of the front burner. See diagram 2.
 - 4) Place the right front log, carefully sliding it down onto the right pins of the front burner. See diagram 3.
 - 5) Distribute the embers along the front burner but do not cover the burner ports and around the logs. See diagram 4.

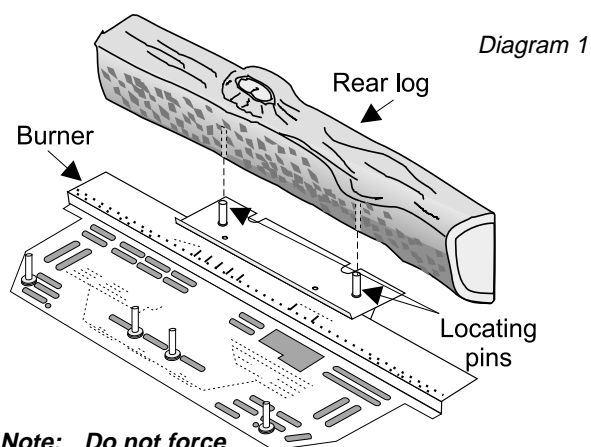

Note: Do not force logs down.

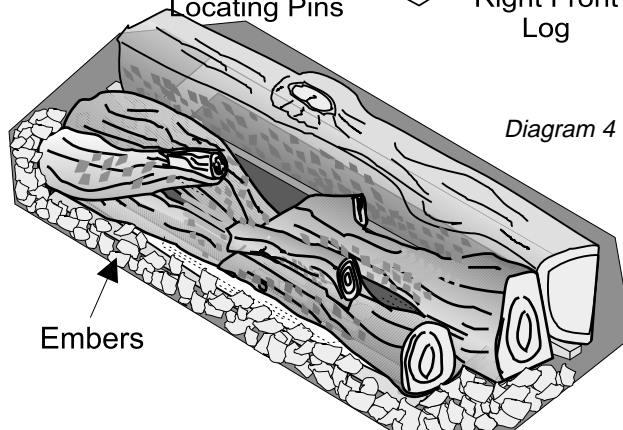
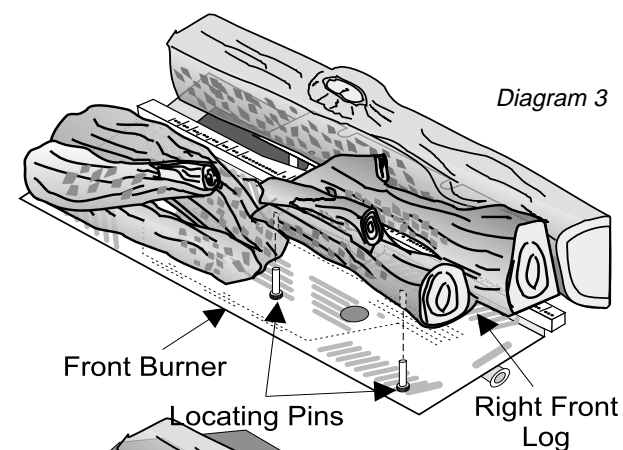
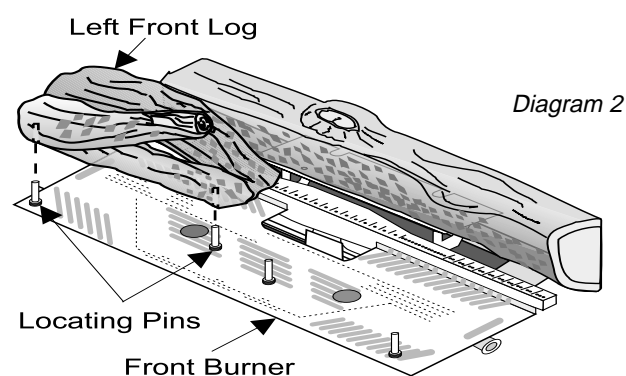

INSTALLATION INSTRUCTIONS

DOOR INSTALLATION

- 1) Open the two side doors.
- 2) Slide the door onto the two hinge pins making sure the two pieces are flush together. See diagram 1.

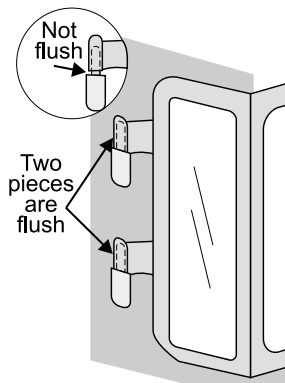

Diagram 1

- 3) Close the door. The latch plate must be centered around the alignment pin. See diagram 2. If the latch plate interferes with the corner of the stove you may want to angle the plate slightly so the door closes more easily.

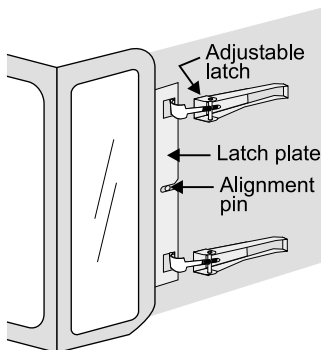

Diagram 2

- 4) The latches should already be at the proper setting. If they are too hard or too easy to close, you may want to adjust them by turning the latch. See diagram 3.
- 5) Remove the blue plastic protective coating.
- 6) Test the seal around the door by placing a piece of paper between the unit and the door, close the door and try to pull the paper out. If it slips out easily, then the door is not properly sealed. Turn the adjustable catch to tighten or loosen the latch. See diagram 3.

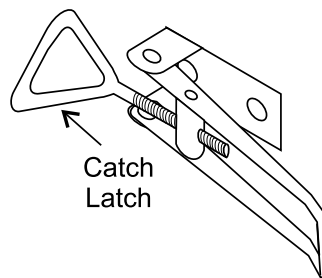

Diagram 3

Note: The door latch may require adjustment as the door gasket material compresses after a few fires and after glass replacement. Turn the latch to tighten or loosen the latch.

OPTIONAL WALL THERMOSTAT

A wall thermostat may be installed if desired. Connect the wires as per the wiring diagrams. Note that the wires are connected to the "TH" on the gas valve. Use chart below to determine the maximum wire length:

Note: Preferable if the thermostat is installed on an interior wall.

Masport offers a programmable thermostat but any CSA, ULC or UL approved millivolt thermostat, 250-750 millivolt rated non-anticipator type thermostat may be used.

CAUTION

Do not connect the millivolt wall thermostat wires to the 240V wires.

Thermostat Wire Table

Recommended Maximum Lead Length (Two-Wire) When Using Wall Thermostat (CP-2 System)	
Wire Size	Max. Length
14 GA.	15.24 m
16 GA.	9.75 m
18 GA.	6.10 m
20 GA.	3.66 m
22 GA.	2.71 m

INSTALLATION INSTRUCTIONS

OPTIONAL REMOTE CONTROL

Use the Masport Remote Control Kits approved for this unit. Use of other systems may void your warranty.

The remote control kit comes with a hand held transmitter, a receiver and a wall mounting plate.

- 1) Choose a convenient location on the wall to install the receiver and the receptacle box (protection from extreme heat is very important). Run wires from the fireplace to that location. Use Thermostat Wire Table.
- 2) Connect the wires as per the wiring diagram on page 15.

CAUTION
Do not connect the millivolt remote control wires to the 240V wires.

- 3) Install alkaline batteries in both the receiver and the transmitter. Install the receiver and its cover in the wall. Switch the hand held remote transmitter to "remote" mode. The remote control is now ready for operation.

FINAL CHECK

Before leaving this unit with the customer, the installer must ensure that the appliance is firing correctly. This includes:

- 1) Check operating pressure (see Data Badge for operating pressure settings).
- 2) If required, adjusting the primary air to ensure that the flame does not carbon. First allow the unit to burn for 15 min. to stabilize.

Natural Gas: 8mm
Propane Full open

- 3) Check for proper draft.

CAUTION

Any alteration to the product that causes sooting or carboning that results in damage to the exterior facia is not the responsibility of the manufacturer.

WIRING DIAGRAM

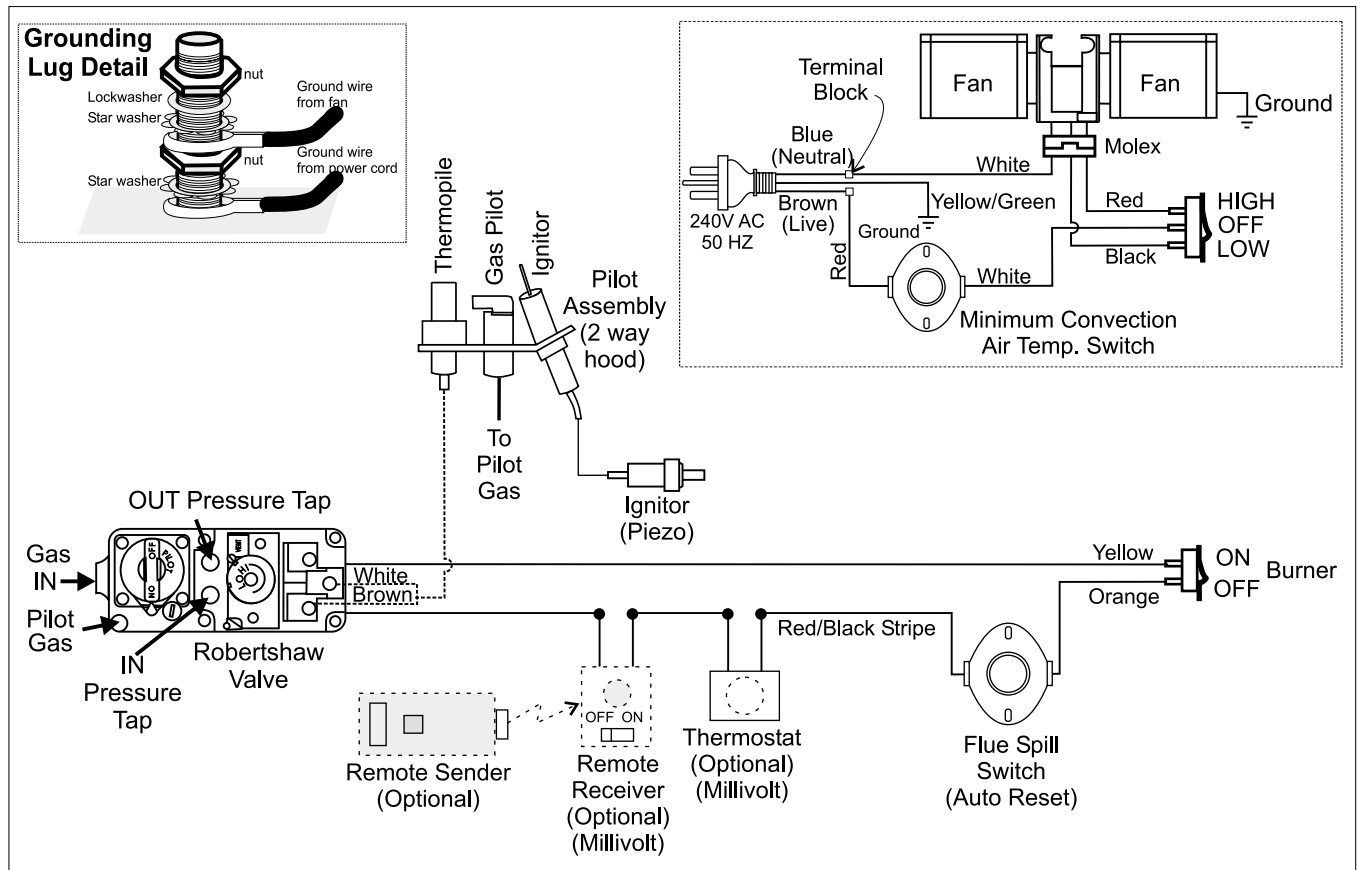

OPERATING INSTRUCTIONS

OPERATING INSTRUCTIONS

Before operating this appliance, proceed through the following check list.

- 1) Read and understand these instructions before operating this appliance.
- 2) **Clean the burner and control compartment of lint and house dust by brushing and vacuuming regularly. At least once a year.**
- 3) Never operate the appliance with any of the glass removed or with the door open.
- 4) Verify log placement. If the pilot cannot be seen when lighting the unit - the logs or the embers have been incorrectly positioned.
- 5) The unit should never be turned off and on without a minimum of a 60 second wait.
- 6) Do not operate with primary guard removed. See below.

THE GUARD IS FITTED TO THIS APPLIANCE TO REDUCE THE RISK OF INJURY FROM BURNS AND NO PART OF IT SHOULD BE PERMANENTLY REMOVED.

FOR PROTECTION OF YOUNG CHILDREN OR THE INFIRM, A SECONDARY GUARD IS REQUIRED.

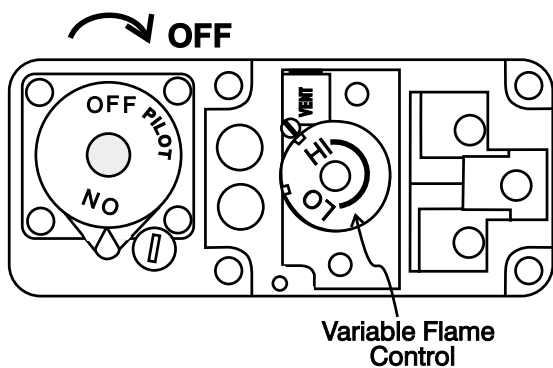

LIGHTING PROCEDURE

IMPORTANT: Gas cock knob cannot be turned from "PILOT" to "OFF" unless it is partially depressed.

- 1) Open the left side door when lighting the pilot, but once the pilot is lit, DO NOT operate the unit with the front glass door open.
- 2) Open the bottom louvre assembly by turning the wing nut and swinging the louvres out. (See page 8 for diagram.)

- 3) If the control knob is in the "OFF" position proceed to Step 5.
- 4) Push in gas control knob slightly and turn clockwise to "OFF". Knob cannot be turned from "PILOT" to "OFF" unless knob is pushed in slightly. Do not force.
- 5) Wait five minutes to allow gas, that may have accumulated in the main burner compartment, to escape. If you do smell gas, follow the instructions on the front of this manual. If you don't smell gas continue on to the next step.
- 6) Turn the gas control counterclockwise to "PILOT".
- 7) Push in control knob all the way and hold in. Immediately push black button on spark igniter until pilot lights. Continue to hold the control knob in for approximately one minute, then release the gas control knob. The pilot flame should continue to burn. If the pilot does not remain lit, repeat operation allowing a longer period before releasing gas control knob.
- 8) Turn gas control knob counterclockwise to "ON".
- 9) Use rocker switch to operate main burner.
- 10) Rotate the variable flame control to adjust the flame height higher or lower.
- 11) Close the bottom louvre assembly and tighten the wing-nut.
- 12) The door must be closed when operating the unit.

SHUTDOWN PROCEDURE

- 1) Use the rocker switch to turn off the main burner.
- 2) Open the bottom louvre assembly by turning the wing nut and swinging the louvres out.
- 3) Push in the gas control knob slightly and turn clockwise to "OFF". Do not force.
- 4) Disconnect all electric power to the appliance if service is to be performed.

OPERATING INSTRUCTIONS

COPY OF THE LIGHTING PLATE INSTRUCTIONS

FOR YOUR SAFETY READ BEFORE LIGHTING

This appliance must be installed in accordance with local codes, if any; if not, follow the current CAN1-B149/ANSI Z 223.1 (Australia: AG601 / New Zealand: NZS 5261)

WARNING: If you do not follow these instructions exactly, a fire or explosion may result causing property damage, personal injury or loss of life. Improper installation, adjustment, alteration, service or maintenance can cause injury or property damage. Refer to the owner's information manual provided with this appliance. For assistance or additional information consult a qualified installer, service agency or gas supplier.

A) This appliance has a pilot which must be lighted by hand, following the instructions below exactly.

B) **BEFORE LIGHTING** smell all around the appliance area for gas. Be sure to smell next to the floor because some gas is heavier than air and will settle on the floor.

WHAT TO DO IF YOU SMELL GAS

- Do not try to light any appliance
- Do not touch any electric switch, do not use any phone in your building
- Immediately call your gas supplier from a neighbours phone. Follow the gas supplier's instructions.
- If you cannot reach your gas supplier, call the fire department.

C) Use only your hand to push in or turn the gas control knob. Never use tools. If the knob will not push in or turn by hand, don't try to repair it, call a qualified service technician. Force or attempted repair may result in a fire or explosion.

D) Do not use this appliance if any part has been under water. Immediately call a qualified service technician to inspect the appliance and to replace any part of the control system and any gas control which has been under water.

This appliance needs fresh air for safe operation and must be installed so there are provisions for adequate combustion and ventilation air.

CAUTION: Hot while in operation. Do not touch. Due to high surface temperatures keep children, clothing and furniture, away. Keep burner and control compartment clean. See installation and operating instructions accompanying appliance.

LIGHTING INSTRUCTIONS

STOP! Read the safety information above on this label.

1) Push in gas control knob slightly and turn clockwise  to "OFF". Knob cannot be turned from "PILOT" to "OFF" unless knob is pushed in slightly. Do not force.

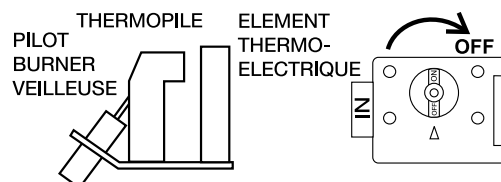

2) Wait five (5) minutes to clear out any gas. If you then smell gas **STOP!** follow "B" in the safety information above on this label. If you don't smell gas, go to the next step.

3) Turn knob on gas control counterclockwise  to "PILOT".

4) Push in control knob all the way and hold in. Immediately push black button on spark igniter until pilot lights. Continue to hold the control knob in for about 1/2 minute after the pilot is lit. Release knob and it will pop back up. Pilot should remain lit. If it goes out, repeat steps 3) and 4). If knob does not pop up when released, stop and immediately call your service technician or gas supplier.

If the pilot will not stay lit after several tries, turn the gas control knob to "OFF" and call your service technician or gas supplier.

5) Turn gas control knob counterclockwise  to "ON".

6) Use rocker switch to operate main burner.

TO TURN OFF GAS APPLIANCE

1) Push in the gas control knob slightly and turn clockwise  to "OFF". Do not force.

2) Turn off all electric power to the appliance if service is to be performed.

DO NOT REMOVE THIS INSTRUCTION PLATE

Made in Canada

908-432

OPERATING INSTRUCTIONS

FIRST FIRE

The first fire in your heater is part of the paint curing process. To ensure that the paint is properly cured, it is recommended that you burn your fireplace for at least four (4) hours the first time you use it with the fan on. When first operated, the unit will release an odour caused by the curing of the paint, the burning off of any oils remaining from manufacturing. Smoke detectors in the house may go off at this time. Open a few windows to ventilate the room for a couple of hours.

The glass panel may require cleaning after the unit has cooled down. **DO NOT ATTEMPT TO CLEAN THE GLASS WHILE IT IS HOT.**

Note: *When the glass is cold and the appliance is lit, it may cause condensation and fog the glass. This condensation is normal and will disappear in a few minutes as the glass heats up.*

DO NOT BURN THE APPLIANCE WITHOUT THE GLASS FRONT IN PLACE.

AUTOMATIC CONVECTION FAN OPERATION

The fan operates automatically, set the fan switch on the side of the faceplate to the desired speed. The fan will turn on as the stove comes up to operating temperature.

After the unit has been turned off and the unit cooled to below a useful heat output range the fan will shut off automatically.

<p>WARNING: Do not spray aerosols in the vicinity of this appliance.</p>

NORMAL OPERATING SOUNDS OF GAS APPLIANCES

It is possible that you will hear some sounds from your gas appliance. This is perfectly normal due to the fact that there are various gauges and types of steel used within your appliance. Listed below are some examples. All are **normal operating sounds** and should not be considered as defects in your appliance.

Fan:

Masport gas appliances use high tech fans to push heated air farther into the room. It is not unusual for the fan to make a "whirring" sound when ON. This sound will increase or decrease in volume depending on the speed setting of your fan speed switch.

Burner Tray:

The burner tray is positioned directly under the burner tube(s) and logs and is made of a different gauge material from the rest of the firebox and body. Therefore, the varying thicknesses of steel will expand and contract at slightly different rates which can cause "ticking" and "cracking" sounds. You should also be aware that as there are temperature changes within the unit these sounds will likely re-occur. Again, this is normal for steel fireboxes.

Fan Thermodisc:

When this thermally activated switch turns ON it will create a small "clicking" sound. This is the switch contacts closing and is normal.

Pilot Flame:

While the pilot flame is on it can make a very slight "whisper" sound.

Gas Control Valve:

As the gas control valve turns ON and OFF, a dull clicking sound may be audible, this is normal operation of a gas regulator or valve.

Unit Body/Firebox:

Different types and thicknesses of steel will expand and contract at different rates resulting in some "cracking" and "ticking" sounds will be heard throughout the cycling process.

IMPORTANT MAINTENANCE INSTRUCTIONS

SERVICE ANNUALLY ONLY BY AN AUTHORISED PERSON

- 1) Clean the burner and control compartment of lint and house dust by brushing and vacuuming at least once a year. When cleaning the logs, use a soft clean brush as the logs are fragile and easily damaged.

During the annual service the burners should be removed from the burner tray and cleaned. Replace logs and embers as per instructions on page 13.

- 2) Clean glass (never when unit is hot), appliance, door and louvres with a damp cloth. Never use an abrasive cleaner. The gold louvres (and optional gold door) may be scratched if abrasives are used to clean them. The heater is finished in a heat resistant paint and should only be refinished with heat resistant paint (not with wall paint). Masport uses Stove Brite Paint - Metallic Black #6309.
- 3) Make a periodic check of burner for proper position and condition. Visually check the flame of the burner periodically, making sure the flames are steady; not lifting or floating. If there is a problem, call an authorised service person.
- 4) The appliance and flueing system must be inspected before use, and at least annually, by an authorised field service person, to ensure that the flow of combustion and ventilation air is not obstructed.
- 5) Keep the area near the appliance clear and free from combustible materials, gasoline, aerosols, and other flammable vapours and liquids.

WARNING: CHILDREN AND ADULTS SHOULD BE ALERTED TO THE HAZARDS OF HIGH SURFACE TEMPERATURE AND SHOULD STAY AWAY TO AVOID BURNS OR CLOTHING IGNITION. YOUNG CHILDREN SHOULD BE CAREFULLY SUPERVISED WHEN THEY ARE IN THE SAME ROOM AS THE APPLIANCE.

CAUTION: ANY SAFETY SCREEN OR GUARD REMOVED FOR SERVICING AN APPLIANCE MUST BE REPLACED PRIOR TO OPERATING THE APPLIANCE.

CLOTHING OR OTHER FLAMMABLE MATERIAL SHOULD NOT BE PLACED ON OR NEAR THE APPLIANCE.

- 6) Each time the appliance is lit, it may cause condensation and fog the glass. This condensation and fog is normal and will disappear in a few minutes as the glass heats up.

Never operate the appliance without the glass properly secured in place or with the door open.

- 7) Periodically check the pilot flames. Correct flame pattern has three strong blue flames: 1 flowing around the thermopile, 1 flowing across the rear burner and 1 reaching towards the front burner (it does not have to be touching the burner).

Note: If you have an incorrect flame pattern, contact your Masport dealer for further instructions.

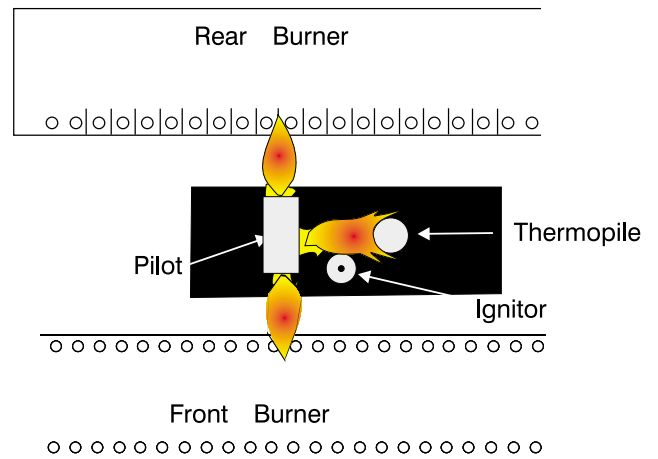

Top View of pilot flame.

Incorrect flame pattern will have small, probably yellow flames, not coming into proper contact with the rear burner or thermopile.

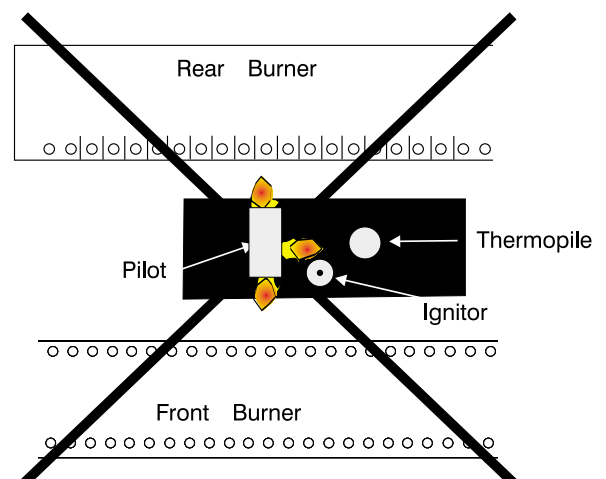

Top View of pilot flame

MAINTENANCE

LOG REPLACEMENT

The unit should never be used with broken logs. Turn off the gas valve and allow the unit to cool before opening door to carefully remove the logs. The pilot light generates enough heat to burn someone. If for any reason a log should need replacement, you must use the proper replacement log. The position of these logs must be as shown in the diagram under Log Installation.

NOTE: Improper positioning of logs may create carbon build-up and will alter the unit's performance which is not covered under warranty.

GOLD-PLATED DOORS

The 24 carat gold plated finish on the door requires little maintenance, and need only be cleaned with a damp cloth. DO NOT use abrasive materials or chemical cleaners, as they may harm the finish and void the warranty. Clean any fingerprints off before turning the unit on. **If gasket seal is not tight - door may discolour.**

DOOR GASKET AND GLASS GASKET

If the door gasket requires replacement use 7/8" diameter oval door gasket. The glass requires 7/8" flat glass gasket. See your Masport Dealer.

LATCH ADJUSTMENT

The door latch may require adjustment as the door gasket material compresses after a few fires and after glass replacement. Turn the adjustable latch to tighten or loosen the latch.

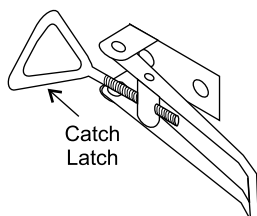

GLASS REPLACEMENT

Your Masport stove is supplied with high temperature, 5 mm Neoceram ceramic glass that will withstand the highest heat that your unit will produce. In the event that you break your glass by impact, purchase your replacement from an authorised Masport dealer only, and follow our step-by-step instructions for replacement.

Removing Glass

Note: Wearing gloves will protect your hands while handling glass.

- 1) Remove the safety screen (Australia only). Remove the door from the unit and place on a soft surface to prevent scratching.
- 2) Pull out the door gasket.
- 3) Remove the 24 nuts holding the glass retainers in place. *Do not remove the nuts underneath the retainers.*
- 4) Remove the door catch plate.
- 5) Remove glass retainers on sides first (3 each side) then remove two center retainers.

Note: Center glass retainers are glued to center glass.

- 6) Remove glass from extrusions. When removing center glass, leave white insulation in place.

Note: Safety screen in Australia only.

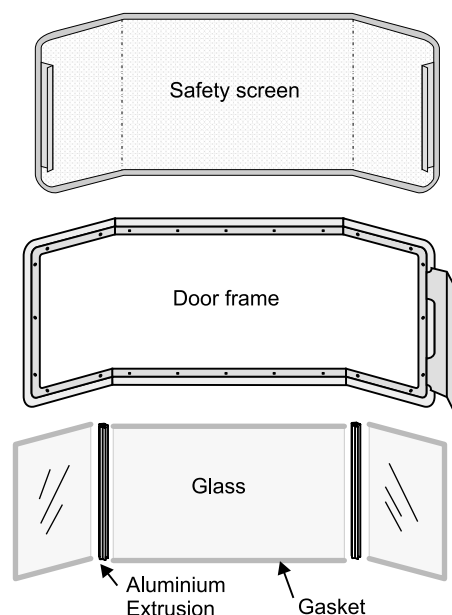

Installing Glass

- 1) Install both center and side glass onto extrusions as per diagram.

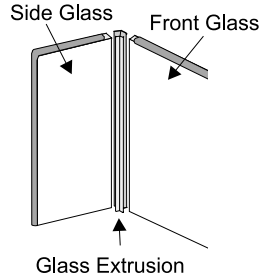

- 2) Place glass assembly into door frame.
- 3) Install retainers by placing 1 drop of glue where previously glued and put in place.
- 4) Install side retainers.
- 5) Install door catch plate.
- 6) Install the 24 nuts loosely, do not tighten yet.
- 7) Tighten side panels nuts using the following procedure :
 - a. tighten top & bottom outside corner nuts (2)
 - b. tighten inside nuts (3)
 - c. tighten top & bottom inside corners (2)
- 8) Tighten the 10 nuts on center glass retainer.
- 9) Repeat step 7 for other side panel.
- 10) Replace new gasket by gluing it in place.
- 11) Install door onto stove and check the seal.

To remove fan:

- 1) Unplug or disconnect power source to stove.
- 2) Remove all logs and the rear log support, then remove the 6 screws holding the access panel in place.
- 3) Disconnect white wire from fan to power cord.
- 4) Disconnect black wire from molex plug to thermodisc.
- 5) Unplug wire harness on left rear side panel (from inside the stove).
- 6) Disconnect green ground wire from fan body.
- 7) Lift fan off of the 2 pins, tip forward and pull through firebox opening.

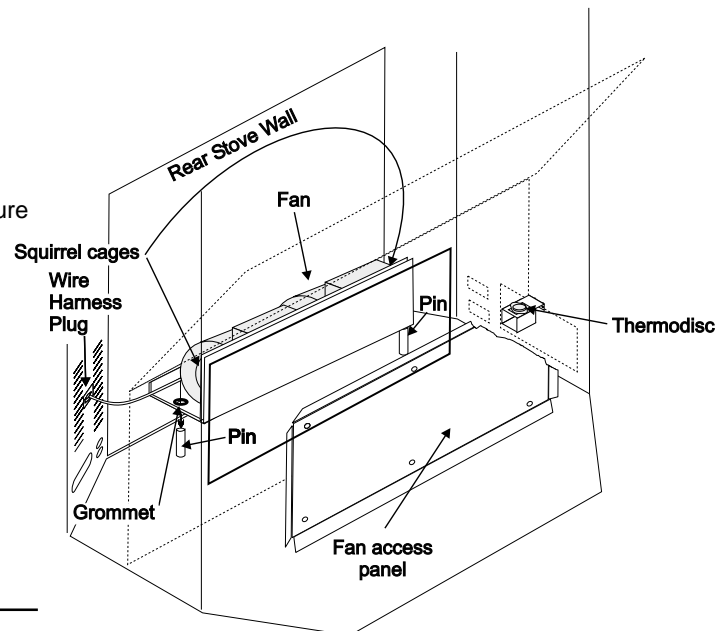

FAN MAINTENANCE

If your fan requires maintenance or replacement, access to the fan is through the access panel on the rear wall of the firebox.
NOTE: the unit MUST NOT be operated without the fan access panel securely in place and correctly sealed.

IMPORTANT
 Disconnect power supply before servicing

WARNING: Electrical Grounding Instructions
 This appliance is equipped with a three pronged (grounding) plug for your protection against shock hazard and should be plugged directly into a properly grounded three-prong receptacle. Do not cut or remove the grounding prong from this plug.

IMPORTANT:

These fans do collect a lot of dust from within your home. Ensure you maintain these fan motors on a regular basis by vacuuming out the fan squirrel cages.

Replacing fan:

Reverse above steps. *Hint for pushing fan down onto pins - rub a bit of dish soap on the grommet so it will slide more easily onto the pin. Check to make sure the fan is seated properly on the pins - try to move the fan back and forth, there should be no noise, if there is check that the grommets haven't come loose.*

Caution: Ensure that the wires do not touch a hot surface.

SERVICE

TROUBLESHOOTING THE GAS CONTROL SYSTEM

Note: Before troubleshooting the gas control system, be sure external gas shut off is in the "on" position.

WARNING: BEFORE DOING ANY GAS CONTROL SERVICE WORK, REMOVE THE GLASS FRONT.

TROUBLESHOOTING GUIDE		
PROBLEM	POSSIBLE CAUSES	CORRECTIVE ACTION
Spark igniter will not light pilot.	Piezo wire loose Defective Piezo igniter. Piezo wire grounding out. Electrode is grounding out and/or wrong location.	<ul style="list-style-type: none"> • Check for spark at electrode and pilot. If no spark, disconnect wire at electrode and put wire to ground and try igniter again. If still no spark follow Piezo wire to Piezo igniter to see where grounding may be occurring. • Bend electrode into pilot so gas may be able to contact spark.
Pilot will not stay lit after carefully following lighting instructions.	Defective thermopile. Defective thermocouple. Thermopile/thermocouple grounding out. Loose thermopile leads. TP-THTP on valve. Defective automatic gas valve.	<ul style="list-style-type: none"> • Check pilot flame, must impinge on thermopile and thermocouple. • Clean and/or adjust pilot so pilot is enveloped around thermopile and thermocouple and correct millivolt reading is set. • Be sure wire connections at gas valve terminals are tight and thermopile and thermocouple are fully inserted into pilot bracket. • One of the switch wires may be grounded. May be grounded to gas appliance or gas supply. • Check thermopile with millivolt meter. Take reading at thermopile terminals of valve TP-TPTH. Should read 250 millivolts minimum while holding valve knob in pilot position with pilot on and wall switch/two way switch off. • Replace if lower than specified minimum. • Turn valve knob to on including pilot. Take reading at TP-TPTH with on/off switch in the on position. Reading should be 100mv or greater. If reading is okay and pilot does not hold, replace gas valve.
Pilot burning, no gas to burner. Valve knob is on. Wall switch is on.	Valve wire connections are loose. Valve wires are defective. Spill switch has not been reset (B-vent F/S). Spill switch is stuck in the open position. (B-vent INS - F/S).	<ul style="list-style-type: none"> • Check two way switch/wall switch for proper connections. Jumper wire across terminals at two way switch/wall switch. If burner comes on, replace switch. • If okay, jumper wire at valve at TH-THTP. If unit turns on, replace wires and/or check where loose wires are.
Frequent pilot outage problems.	Pilot flame may be too low or blowing high causing the pilot safety to drop out. Two way switch wires may be grounding out. Thermopile and/or thermocouple may be grounding out.	<ul style="list-style-type: none"> • Clean and/or adjust pilot for maximum flame impingement on thermopile and/or thermocouple and correct millivolt reading is set. • Trace wires from valve to two way switch/wall switch for possible grounding against gas appliance and/or gas supply. • Trace thermopile wires from valve to thermopile for possible grounding against gas appliance and/or gas valve. • Follow same steps for thermocouple.
<p>Note: For service technicians only. See the Masport Troubleshooting Guide for more detailed information. (Troubleshooting Masport Gas Products - Part # 908-439.)</p>		

ABNORMAL OPERATION

If the main burner does not light but pilot stays on shut down heater and contact your dealer

If excessive carbon on logs or glass contact your dealer

THE MASPORT EXPRESS WARRANTY

All new Masport Gas appliances are warranted, subject to the following conditions, to be free from defects in material or workmanship under normal use. The Express Warranty on all parts, including firebox components but excluding fans, flues and flue accessories is two years from date of original purchase as well as labour costs involved in the repair or replacement. The Express Warranty on fans, flues and accessories is for a period of twelve months from date of original purchase and includes labour costs involved in the repair or replacement.

This Express Warranty applies only with respect to defects in material and workmanship under normal and proper use of the NEW UNIT in its unmodified condition. Masport's obligation under this Express Warranty is limited to the repair or replacement, at its option, by an approved Masport Gas Service Agent (Retailer) of any part found to be defective in material or workmanship.

Labour costs involved in the repair or replacement are also covered under this Express Warranty as per the time condition outlined.

If an approved Masport Gas Service Agent is requested to attend on a service call that is not covered under this Express Warranty, a call out charge may be applicable, regardless of whether a repair is carried out or not.

Masport can accept no obligation whatsoever for any incidental, consequential or special damages or expenses resulting from any product defect. This Express Warranty applies from the date of original purchase, applies to the original purchaser, and is not transferable. The decision to repair or replace defective components will be made by Masport or its agent and actioned by an approved Masport Service Agent.

This Express Warranty Does Not Cover:

1. Defects, malfunctions or failures caused by incorrect installation, normal wear and tear, misuse, neglect, accidental damage or failure to follow the fuel selection, product operating and maintenance instructions, or resulting from installations, repairs or modifications to the equipment carried out by unauthorised persons.
2. Defects, malfunctions or failures caused by an act or omission of other persons after the product has left Masport's control.
3. The costs of collection and delivery of the equipment.
4. The cost of labour or materials as a consequence of faulty installation of gas supply line, flue, burner or log settings, or non-compliance with local codes.

The Express Warranty is not intended to exclude any rights the purchaser may have under the laws of the place, state, or country of purchase. Nothing in this Express Warranty limits or restricts any other statutory right or remedy available to the purchaser.

How You Obtain Warranty Service:

Provide proof of the date of purchase. Should the need for a warranty claim arise reasonable proof of the purchase date is required therefore you should retain your sales receipt. Where flueless appliances are not permanently installed, they should be returned to a Service Agent for evaluation.

Make the faulty part(s) available for inspection by Masport and/or its agents so that the validity of the claim can be established by them.

Australia Distributor:

Masport Pty Limited
P.O. Box 533
Mordialloc 3195
Victoria

New Zealand:

Masport Limited
P.O. Box 14-349
Panmure
Auckland 6

For your own records, please complete the following:

Model: _____	Serial Number: _____
Retailer: _____	

Purchase Date: _____	