

Owners & Installation

Masport®

Seville & Naples

Model: Seville Natural Gas
Seville L.P.G.

Naples Natural Gas
Naples L.P.G.

PLEASE KEEP THESE INSTRUCTIONS
FOR FUTURE REFERENCE



Manual

LISTINGS AND CODE APPROVALS

These gas appliances have been tested in accordance with AG 103, NZS 5262 and have been certified by the Australian Gas Association for installation and operation as described in these Installation and Operating Instructions.

Your unit should be serviced annually by an authorised service person.

WARNING:

Improper installation, adjustment, alteration, service or maintenance can cause injury or property damage. Refer to this manual. For assistance or additional information consult an authorized installer, service agency or the gas supplier.

FOR YOUR SAFETY

Do not store or use gasoline or other flammable vapours and liquids in the vicinity of this or any other appliance.

Installation and service must be performed by an authorized installer, service agency or the gas supplier.

FOR YOUR SAFETY

What to do if you smell gas:

- Do not try to light any appliance
- Do not touch any electrical switch: do not use any phone in your building.
- Immediately call your gas supplier from a neighbour's phone. Follow the gas supplier's instructions.
- If you cannot reach your gas supplier, call the fire department.

Head Office - Australia

P.O. Box 553
Mordialloc 3195
Ph. (03) 9586-7777
Fax. (03) 9586-2980

Head Office - New Zealand

1-37 Mt Wellington Hwy. Panmure,
P.O. Box 14 349
Auckland 6.
Ph. (9) 570-9009
Fax. (9) 527-1294

MASPORT INBUILT GAS FIREPLACE

TO THE NEW OWNER

Congratulations! You are the owner of a state-of-the-art Gas Inbuilt by Masport. The Masport Gas Fireplace Series of hand crafted appliances has been designed to provide you with all the warmth and charm of a fireplace at the flick of a switch. This model has been approved by the Australian Gas Association for both safety and efficiency. As it also bears the Masport brand, it promises to provide you with economy, comfort and security for many trouble free years to follow.

Please take a moment now to acquaint yourself with these instructions and the many features of your Masport Fireplace.

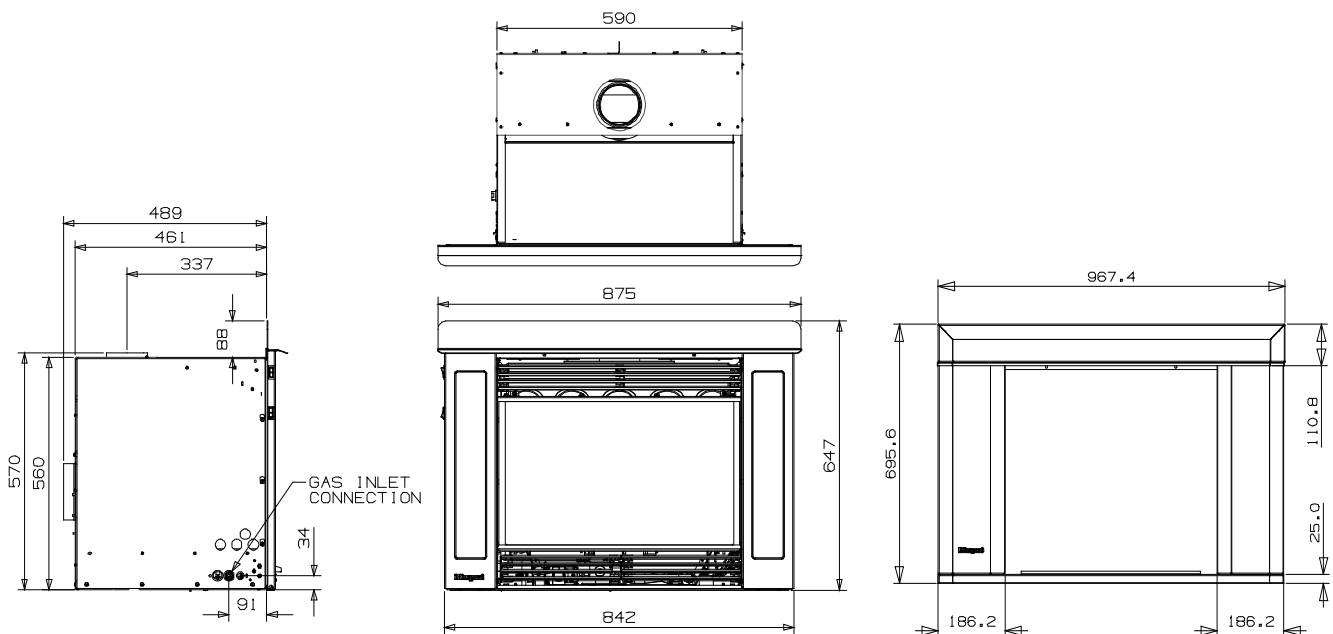

This book contains important information. Please keep it in a safe place for future reference.

THE INSTRUCTIONS IN THIS MANUAL APPLY TO; MASPORT INBUILT - SEVILLE AND NAPLES GASFIRES

THE MODELS COVERED ARE:-

MG5000 INBUILT LP, for use with Liquid propane gas (LPG)
AND MG5000 INBUILT NG, for use with Natural gas

IMPORTANT: SAVE THESE INSTRUCTIONS

The Masport Gas Fireplace must be installed in accordance with these instructions. Carefully read all the instructions in this manual first. Consult the "authority having jurisdiction" to determine the need for a permit prior to starting the installation.

Note: *Failure to follow these instructions could cause a malfunction of the heater, which could result in death, serious bodily injury, and/or property damage. Failure to follow these instructions may also void your fire insurance and/or warranty.*

FOR YOUR SAFETY

This appliance requires air for proper combustion. Always provide adequate combustion and ventilation air.

MATERIALS and INSTALLATION are to comply with AG 601, NZS 5261 and all relevant building, gas-fitting, electrical and other Statutory Regulations.

INSTALLATION MUST BE CARRIED OUT ONLY BY AN AUTHORIZED PERSON.

GAS PIPE TESTING

The appliance must be isolated from the gas supply piping system by closing its individual manual shutoff valve (not supplied with heater) during any pressure testing of the gas supply piping system at test pressures equal to or greater than 3.45 kPa.

SPECIFICATIONS

Specifications: 35MJ/h

Fuel: Natural Gas or Propane
Electrical: 230-250 volts AC system
Fan/Blower 2 speed
Logs: Ceramic fibre, 4 per set

Before installation commences, check the data plate on the appliance to verify that it is the correct type to suit your gas and also that the gas consumption rate is correct for your application.

IMPORTANT REQUIREMENTS

Installation and repair is to be carried out **ONLY** by an authorized person.

- 1) The appliance installation must conform with local codes or in the absence of local codes, to AG601, NZS5261. This appliance **MUST** be installed by an authorized gas fitter technician only.
- 2) **Installation and repair should be done by an authorized service person or agency.**
- 3) The appliance should be inspected before use and at least annually by an authorized service person. More frequent cleaning may be required due to excessive lint from carpeting, bedding material, etc. It is imperative that control compartments, burners and circulating air passageways of the appliance are kept clean and free from excessive lint.
- 4) See general construction and assembly instructions. This appliance may only be installed in a vented, non-combustible fireplace. The appliance and flue should be enclosed when installed or passing through a living area, where children may come in contact with it.
- 5) Always connect this fireplace to a flue pipe terminating outside the building envelope. Never vent to another room. Make sure that the flue pipe is properly sized and is of adequate height to provide the proper draft.
- 6) Inspect the fluing system annually for blockage and any signs of deterioration.
- 7) If the glass is removed for servicing it must be replaced prior to operating the appliance.
- 8) To prevent injury, do not allow anyone who is unfamiliar with the operation to use the fireplace.
- 9) Always turn off the gas valve before cleaning. For relighting, refer to lighting instructions. Keep the burner and control compartment clean by brushing and vacuuming at least once a year.

When cleaning the logs, use a soft clean paintbrush as the logs are fragile and easily damaged.
- 10) Clean appliance with a damp cloth (never when unit is hot). Never use an abrasive cleaner. The glass should be cleaned with a gas fireplace glass cleaner.
- 11) Make a periodic check of burner for proper position and condition. Visually check the flame of the burner periodically, making sure the flames are steady, not lifting or floating. If there is a problem call an authorized service person.

MATERIALS REQUIRED

No mains voltage electric power supply is required for the gas control to operate. A 240 Volt AC power cord is hooked up to the fan switch and blower. Plug 3-wire cord into a suitable receptacle. Do not cut the ground terminal off under any circumstances.

When connected with 240 volts, the appliance must be electrically grounded in accordance with local codes.

INSTALLATION SEQUENCE

The Masport Gas Insert is installed in the steps as listed below. Detailed instructions follow.

- 1) Check the clearances to ensure that the fire will fit the fireplace recess and clearances to combustibles will be maintained. See page 7.
- 2) Prepare the fireplace recess. See page 7.
- 3) Install the flue or flexi-liner in accordance with AG 601 or NZS 5261, refer to instructions provided with the flue kit.
- 4) Install the gasfire into the fireplace recess and connect to the flue system. See page 8.
- 5) Make the gas connections and electrical connection for fan. See page 8.
- 6) Assemble and install the fascia and fan switch etc. See pages 9 & 10.
- 7) Remove the glass/window and install the embers etc. See page 10 & 11.
- 8) Re-install the glass front (Flush or Bay). See pages 10 & 11.
- 9) Install louvres (Flush or Bay).
- 10) **Final check:** Before leaving this unit with the customer, the installer must ensure that the appliance is firing correctly. This includes:
 - a) Checking the manifold pressure. See page 11.
 - b) Clocking the appliance to ensure the correct firing rate.
 - c) Adjusting the primary air, if required, to ensure that the flame does not carbon on the components.
 - d) Ensuring that the flue is drawing correctly.

DANGER

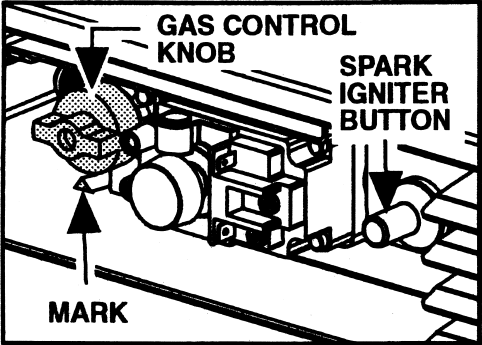

TO TURN OFF THE GAS

- Turn the Gas Control knob clockwise to 'Pilot'—gently push in the knob and turn to 'Off'.

LIGHTING INSTRUCTIONS

1. Turn the gas off—see above.
2. Wait 5 minutes. **If you then smell gas**

stop! Leave the building directly and call your service provider. If not...

3. Turn the Gas Control knob anticlockwise to 'Pilot'.
4. Push in and hold the Gas Control knob. With your other hand simultaneously push and release the red Spark Igniter button until the pilot lights.
 - Continue to hold the Gas Control knob in for about 30 seconds.
 - If the pilot goes out repeat steps 1-4.

NOTE: If the Knob does not pop out after being released or the pilot will not light turn and push the Gas Control knob to 'Off' and call your service provider.

5. Turn the Gas Control knob anticlockwise to 'On'
6. Use the rocker switch on the top left side of the fascia to operate the main burner.

(Copy of Lighting Instruction plate)

INSTALLATION REQUIREMENTS

For safe installation the following matters must be attended to;

- The fireplace and chimney must be thoroughly cleaned and checked for soundness.
- The chimney must not connect to a solid fuel-burning appliance.
- The fireplace recess must have a non-metallic heat resistant surround (e.g. masonry) extending at least 550mm each side of the recess centerline and up at least to the mantel above the base of the fireplace recess.
- A flue pipe or flexiliner must be fitted right up the chimney and exit at the top and be terminated with an approved gas cowl.

CLEARANCES

The minimum fireplace clearances for the Masport Inbuilt Gasfires are shown in the following diagram:

Masonry fireplaces

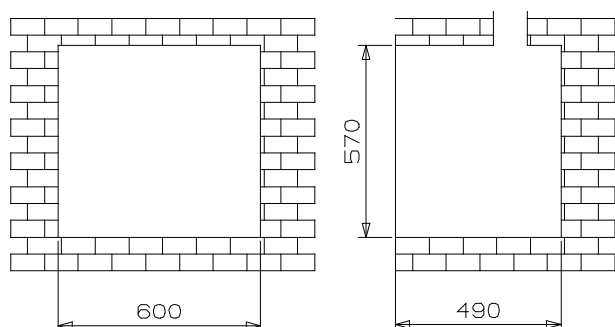

Measure the fireplace recess and remove bricks as necessary to accept the firebox outer case. Clear away any loose rubble and inspect before installing the fireplace.

All Masport heaters are tested to New Zealand and Australian standards. Clearances are for fire hazard only. For durability of finishes and surfaces you should contact the relevant manufacturer for their specification. Masport accepts no responsibility for the deterioration of surface's or finishes.

NON MASONRY FIREPLACE RECESS (ZERO CLEARANCE INSTALLATION)

Refer to the Zero Clearance Kit Manual for details on installations in non-masonry recesses.

Clearances to Combustibles (mm)

Fascia Type;

	Mantel (Shown)	Bevelled
(From Unit)		
Sides A	225	225
Ceiling B	1500	1500
Mantel C	1000	1150
(From Fascia)		
	(648 x 842)	(682 x 842)
Sides D	100	39
Ceiling E	1410	1345
Mantel F	350	425

The following are for both Fascia options;

Max. Mantel Width G	305
Hearth Height H	0
Hearth Depth I	405 *
Hearth Width J	1000

* **Hearth Depth "I" can be reduced to 300mm if Hearth Height "H" is increased to a min. Of 30mm.**

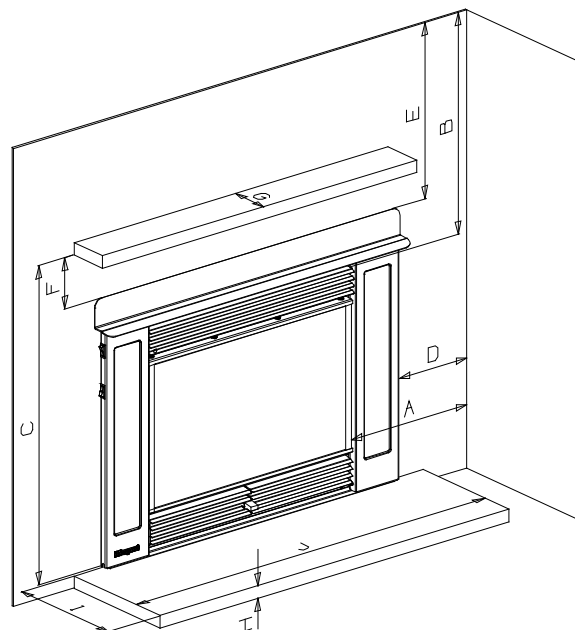

NOTE: Mantel clearances and hearth requirements for Installation into a Zero Clearance Kit are different. Please refer to the Zero Clearance Kit Manual for details.

FLUING

THE APPLIANCE MUST NOT BE CONNECTED TO A CHIMNEY FLUE SERVING A SEPARATE SOLID FUEL BURNING APPLIANCE.

This appliance is designed to attach to a 100mm diameter type B-Vent or approved flexi-liner or listed gas fuel type flue liner running the full length of the chimney. A minimum flue height of 3.6m is recommended. B-Vent must be supported by a flue support - supplied by flue manufacturer. The Masport Insert incorporates its own internal draft hood, so no additional external draft hood is required.

Periodically check that the flue is unrestricted and an adequate draft is present when the unit is in operation.

Flue Spillage

A "spillage" test must be made before the installed unit is left with the customer.

The flue draught on Australian models can be checked by holding a lighted match just inside the open end of the spill tube after the heater has been running for at least five minutes.

Start all exhaust fans in the home and then close all external doors and windows.

The tube, approximately 12mm diameter, is located at the top right hand corner of the outer cabinet (behind the top louvre assembly). If the match flame is not drawn into the tube but is blown back outwards the flue system is not drawing correctly, (refer to the diagram below). Do not operate the heater with inadequate draught as dangerous combustion products could be discharged into the room.

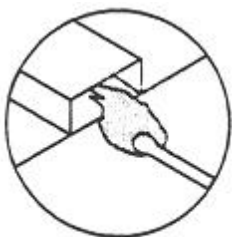

normal draft

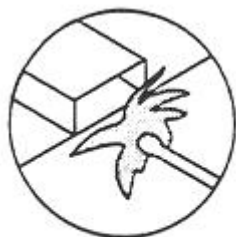

**downdraft
or block flue**

Install to AG 601, NZS 5261 or local codes.

Fire Installation

- 1) Slide the fireplace into the recess and adjust the case position so that it is level and its front top flange is in line with the face of the surround. Where seismic restraint is necessary, screw the bottom of the case to the base of the fireplace recess.

- 2) If space above the case for positioning and fixing the flue is limited, access can be provided by first removing the top louvre by lifting it upwards and outwards.
- 3) Then remove the 2 screws holding the top sliding panel located at each side of the fire. The top front section of the case can now slide out as illustrated below to increase access.

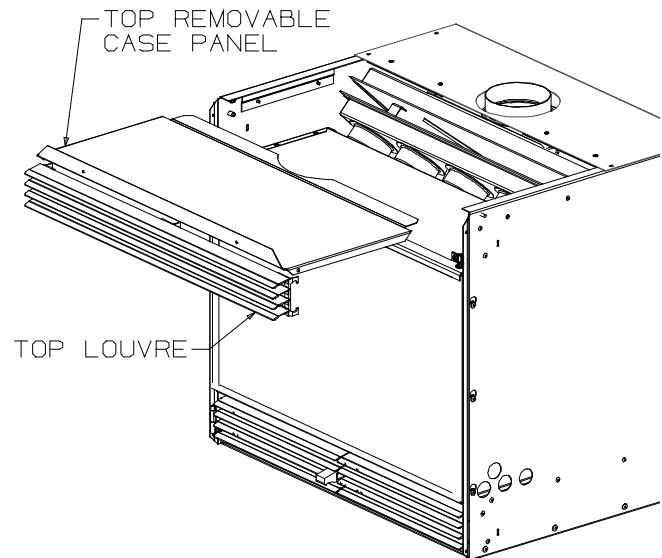

- 4) Attach the flue to the flue spigot on the draft hood. The flue collar of the appliance will fit inside a standard flue and may be fastened directly to the flue by sheet metal screw or a B-Vent, single wall flue connector.
- 5) Once the flue is connected, reassemble the fire.

Note: *Final gas connection should be after unit is in place to avoid damage to line when pushing the unit into position.*

Combustion and Ventilation Air

WARNING: This appliance needs fresh air for safe operation and must be installed with provisions for adequate combustion and ventilation air available to the room in which it is to be operating.

Air for combustion is drawn in through the front of the unit; therefore, the front of the unit must be kept clear of any obstructions.

GAS CONNECTION

GAS CONNECTION WARNING:

Only persons licensed to work with gas piping may make the necessary gas connections to this appliance.

The gas connections are 3/8" flare for NZ and 1/2" flare for Australia.

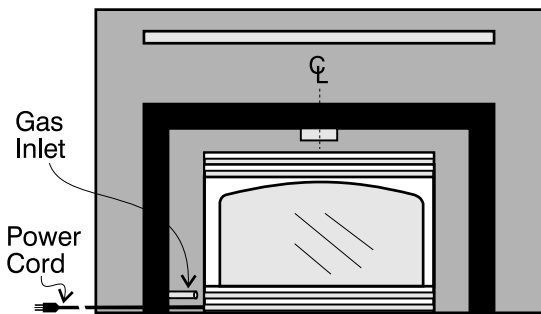

- 1) Locate the center point where the flue will pass through the chimney above the appliance. Move the appliance into the exact location where it is to be installed. Ensure that the Insert is level.
- 2) Two easily accessible test points are provided on the front of the gas control valve, and is easily accessible for a test gauge connection (See diagram on page 11).
- 3) Once the gas has been connected, ensure that the pilot valve is in line with the burner.

CAUTION: If the glass has been removed for servicing, it must be replaced prior to operating the appliance.

FASCIA INSTALLATION

Mantel Fascia

- 1) Lay the fascia panels flat, face down on something soft so they don't scratch.
- 2) Take the top mantel and align the holes in it with the holes in the side panels. Using the flat head screws provided, attach the top of the side panel's to the mantel (the holes in the mantel are slightly larger than the holes in the side panel to facilitate easier installation). See Fig 1.

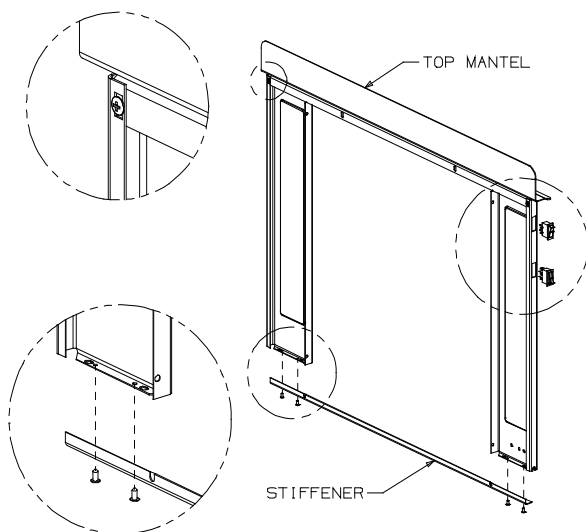

Fig 1
Rear View

Hint: Don't tighten the screws down completely at this point, continue on with steps 3 and 4 and do a trial fit to the unit. Make any necessary adjustments and when it fits properly then tighten down the screws.

- 3) Next the Fascia stiffener is attached to the Fascia. Attach the stiffener to the bottom of the fascia side panels with the screws provided. See Fig 1 (bottom).
- 4) If not already fitted, push the Masport logo badge into the holes in the bottom left corner of the fascia and attach it using the clips provided. See Fig 2.

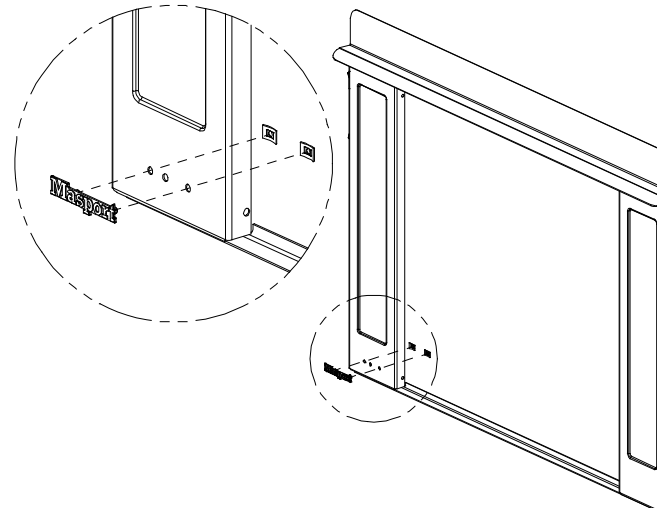

Fig 2

- 5) Take the 2 switches supplied with the fire and push them into the rectangular switch holes in the left-hand side of the fascia. The 3 terminal switch must be in the bottom hole and the 2 terminal switch must be in the top hole. Refer Fig 3.

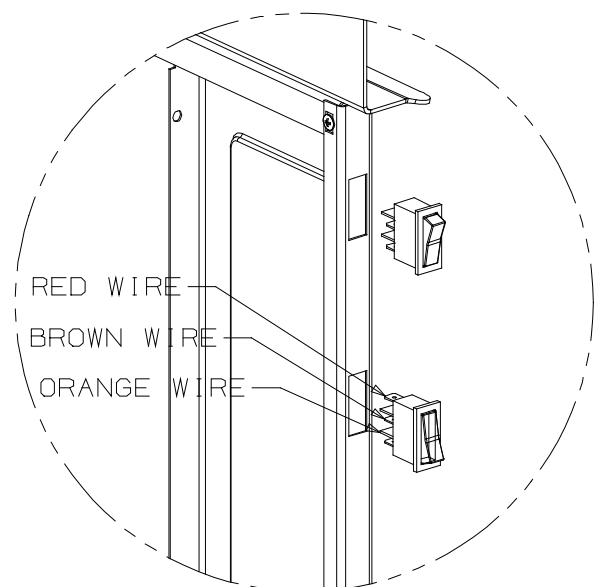

Fig 3

- 6) Connect the fan switch wires by taking the orange, brown and red wires with the female ends (in the thick wiring loom) and connect them to the fan switch (i.e. the 3 terminal bottom switch) noting the following positions. Connect the brown wire to the middle terminal, connect the red wire to the top terminal and connect the orange wire to the bottom terminal. Refer to 240V wiring diagram on page 4. And fig 2, (bevelled fascia).
 - 7) Connect the ON/OFF switch wires by taking the black and white wires with the female ends and connect them to the ON/OFF switch (i.e. the top 2 terminal switch). Refer to the millivolt-wiring diagram on page 4 for more details.
 - 8) Tuck the wires into the faceplate to keep them away from the insert. Ensure that the wires do not touch the side of the unit.
 - 9) The power cord should be run behind the fascia panel and out through the slot in the bottom of the fascia.
 - 10) Attach the fascia panels to the insert body using 4 black screws.
- 4) Connect the fan wires -Orange, brown and red to the bottom fan switch, noting the following positions.

- Brown wire	to	middle terminal,
- Orange wire	to	top terminal,
- Red wire	to	bottom terminal.
 - 5) Connect the black and white wires to the on/off switch.
 - 6) Ensure that the wires are away from the side of the fireplace. The power cord should be run behind the fascia panel and out through the hole in the side of the fascia.

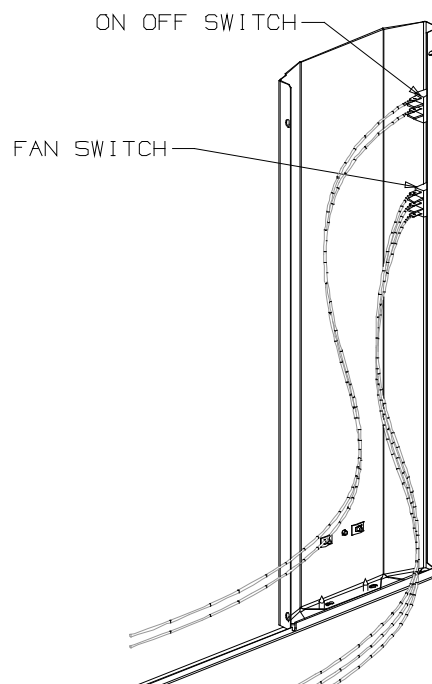

Fig 2.

Bevelled Fascia

- 1) Lay the fascia panels on their front on something soft to prevent them from being marked.
- 2) Align the bottom flange of each side panel with the corresponding end of the bottom rail. Using the self-tapping screws provided, attach the bottom rail to the bottom flanges of the side panels. Only loosely tighten the screws. See Fig 1.

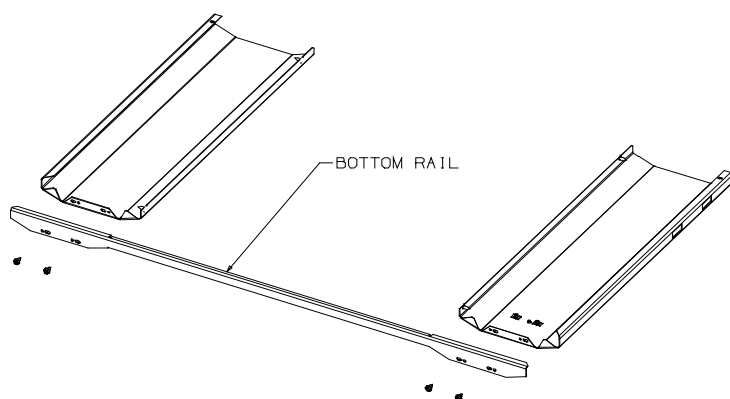

Fig 1.

- 3) There are two switches supplied with the fascia. Insert these into the rectangular holes in the left in the top edge of the LH side panel. The fan switch (3 terminals) must be in the bottom hole and the on-off switch (2 terminals) must be in the top hole. See Fig 2.
- 7) Offer the assembly up to the fireplace to obtain the correct width for the side panel spacing keeping the inside flanges of each panel on the inner side of the mounting flange of the fireplace. Carefully remove the assembly and continue to tighten the screws fastening the bottom rail to the side panels.
- 8) Offer the assembly up to the fireplace once more and secure through the two holes on the inner edges of each fascia side panel using the self tapping screws provided. See Fig 3.

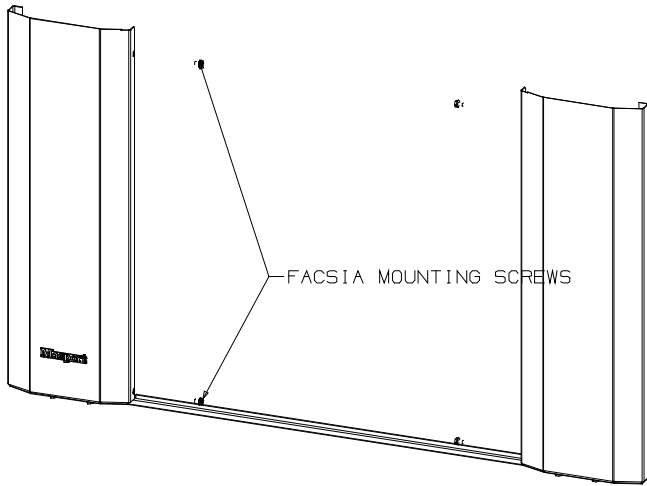

Fig 3.

- 9) Lower the top panel assembly into place with the locating prongs pointing down so that they fit neatly inside the top edges of each side panel. Fasten the top panel to the fireplace through the two holes in the lower flange of the top panel assembly. See Fig 4.

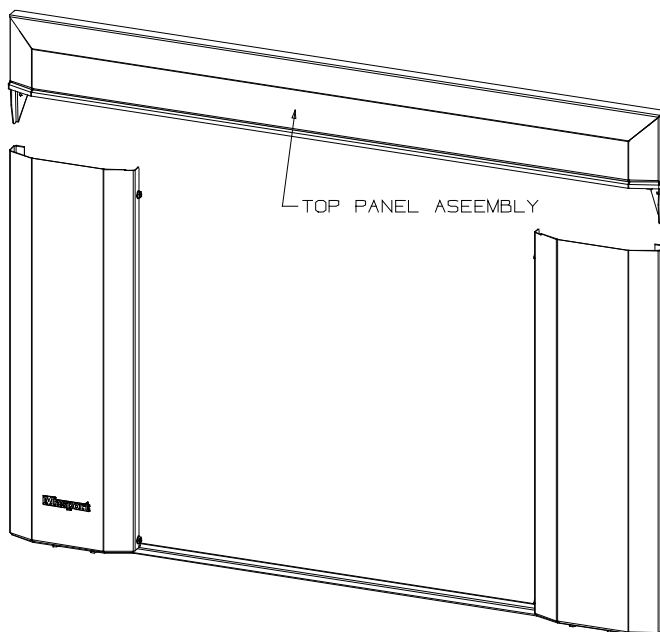
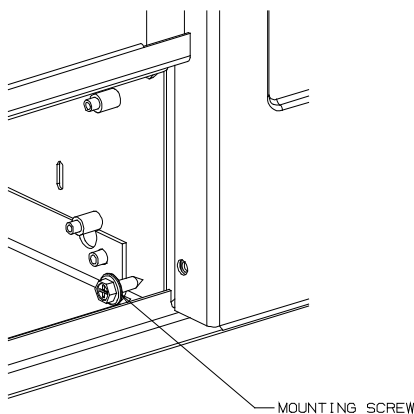
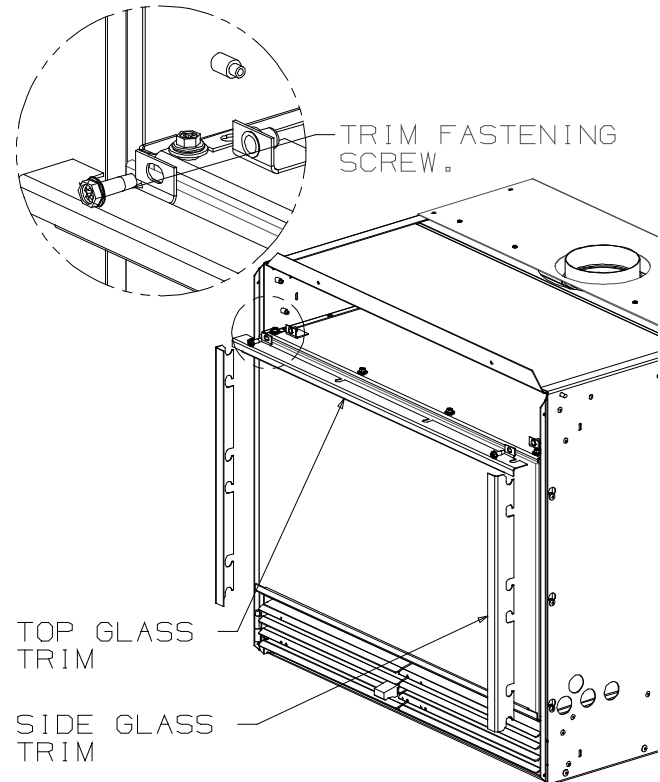

Fig 4.



FLUSH FRONT GLASS REMOVAL/INSTALLATION

- 1) Remove the top louvre by lifting it upwards and outwards to clear the retaining pins.
- 2) Remove the two trim fastening screws, one at either end of the top trim as per the diagram below and remove the top gold trim.



- 3) Remove the 2 black cover trims one at either end of the glass by lifting them upwards and then out. Pull the top of the trim forward before the bottom.
- 4) This will now free the glass for removal from the fire and give access to the logs, burner etc.

BAY FRONT GLASS REMOVAL/INSTALLATION

- 1) Remove the top louvre by lifting it upwards and outwards to clear the retaining pins.
- 2) Remove the bottom RH louvre by lifting it upwards and outwards to clear the retaining pins.
- 3) Open the LH bottom louver and lift it off it's hinge.

- 4) Remove the two window fastening screws, one at either end of the window as per the diagram below.
- 5) This will now free the glass for removal from the fire by swinging the top outwards slightly and lifting the bottom edge clear of its retaining channel. This will give access to the logs, burner etc.

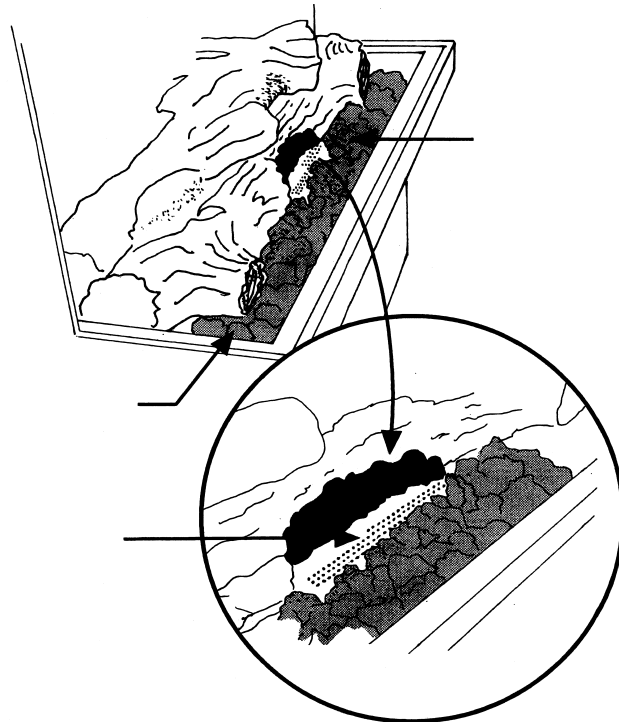
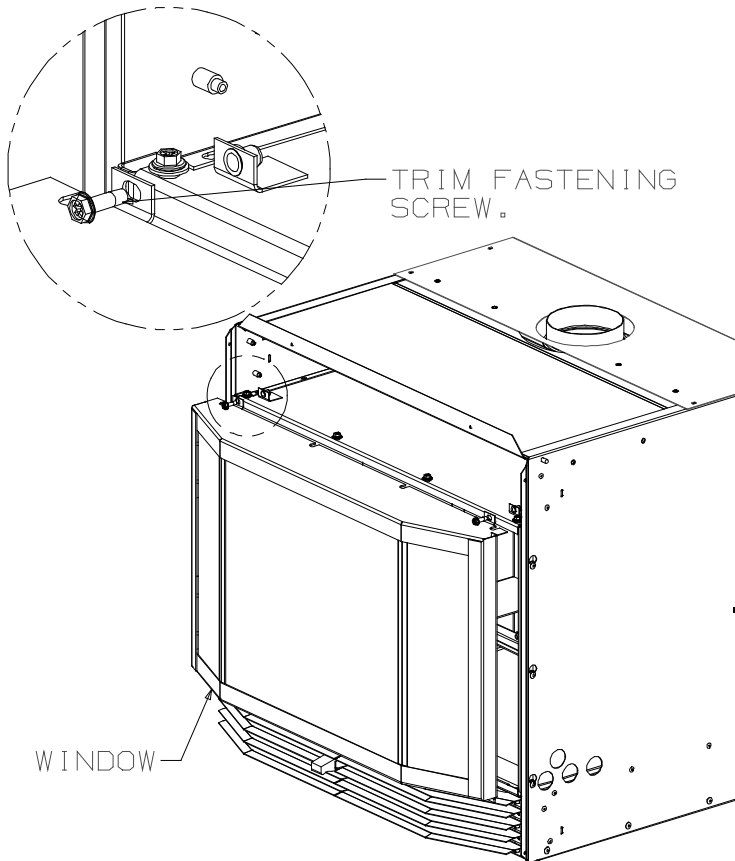

- 4) Re-install the flush or bay window. Do not operate the appliance with the window removed.

GAS PRESSURE TEST

The unit is preset to give the correct gas input at the specified manifold pressures shown on the label. The maximum gas manifold pressure is:

Natural Gas	0.80 kPa
Propane	2.58 kPa

The manifold pressure is controlled by a regulator built into the gas control, and should be checked at the pressure test point. The pressure check should be carried out with the unit burning and the setting should be as above.

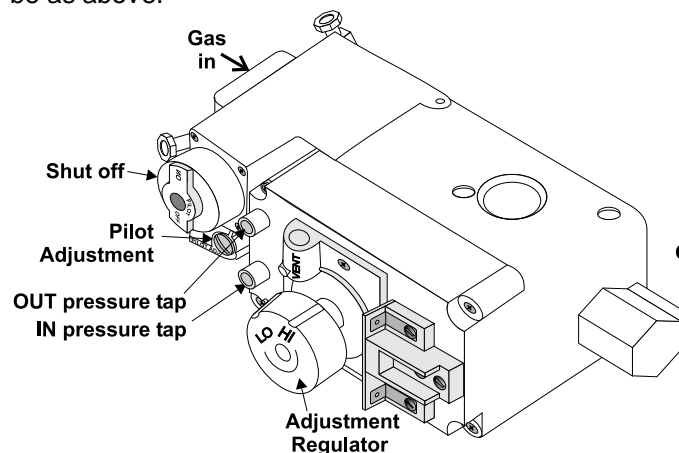

EMBER PLACEMENT

- 1) Inspect the logs before ember installation. If the logs are broken, do not use the unit until they are replaced. Broken logs can interfere with the pilot operation, combustion, etc.
- 2) Once either the flush or bay windows are removed as per the above instructions the embers can be placed in the fire.
- 3) Place embers in front of the burner as shown. Do not cover the small round burner ports. Embers can be placed along the front of the tray and down the sides to hide the black steelwork etc.

OPTIONAL WALL THERMOSTAT INSTALLATION

A wall thermostat may be installed if desired.

Note: It is preferable that the thermostat be installed on an interior wall.

Use a CSA, UCL or UL approved millivolt thermostat, 250-750 millivolt rated. A non-anticipator type thermostat must be used.

Masport Part Number
988424 Programmable/Digital Wall Thermostat
988425 Manual Wall Thermostat (NZ only)

OPTIONAL REMOTE CONTROL INSTALLATION

Use the Optional Masport Remote Control Kit approved for this unit. Use of other systems may void your warranty.

The remote control kit comes with a hand held transmitter, a receiver and a wall mounting plate.

- 1) Choose a convenient location on the wall to install the receiver and the receptacle box (protection from extreme heat is very important). Run wires from the fireplace to that location. (Do **NOT** install behind louvres)
- 2) Connect the two wires to the gas valve. (Refer to instructions supplied with the remote control for detailed installation instructions)

OPERATING INSTRUCTIONS

Before operating this appliance, proceed through the following checklist.

- 1) Read and understand these instructions before **operating** this appliance.
- 2) Check to see that all wiring is correct and enclosed to prevent possible shock.
- 3) Check to ensure there are no gas leaks.
- 4) Make sure the glass is in place. Never operate the appliance with the glass removed.
- 5) Verify that all fluing and the flue cap is unobstructed.

- 6) Verify log placement. If the pilot cannot be seen when lighting the unit - the logs or the embers have been incorrectly positioned.
- 7) The unit should never be turned off and on again without a minimum of a 60-second wait.
- 8) Each time the appliance is lit, it may cause condensation and fog the glass. This condensation and fog is normal and will disappear in a few minutes as the glass heats up.

DO NOT BURN THE APPLIANCE WITH THE GLASS ASSEMBLY REMOVED.

LIGHTING PROCEDURE

IMPORTANT: Gas cock knob cannot be turned from "PILOT" to "OFF" unless it is partially depressed.

- 1) On NZ models, open the left hand bottom louvre assembly by lifting the wooden knob and pulling gently.
- 2) If the control knob is in the "OFF" position proceed to Step 5.
- 3) Push in gas control knob slightly and turn clockwise to "OFF". Knob cannot be turned from "PILOT" to "OFF" unless knob is pushed in slightly. Do not force.

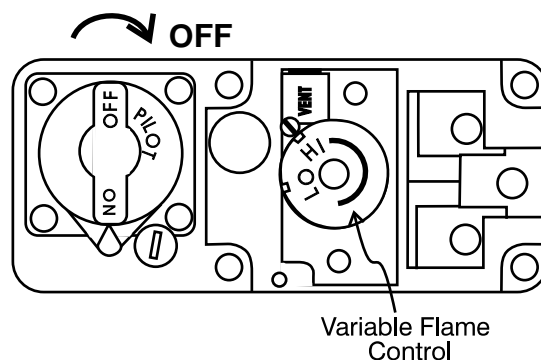

- 4) Wait five minutes to allow gas that may have accumulated in the main burner compartment, to escape. If you do smell gas, follow the instructions on the front of this manual. If you don't smell gas continue on to the next step.
- 5) Turn the gas control counter clockwise to "PILOT".
- 6) Push in control knob all the way and hold in. Continually push and release the red button on spark igniter until pilot lights. The pilot is located at the center bottom of inside the firebox behind the front log. Continue to hold the control knob in for approximately 15 seconds, then release the gas control knob. The pilot flame should continue to burn. If the pilot does not remain lit, repeat

operation allowing a longer period before releasing gas control knob.

- 7) With the pilot flame established turn the gas control knob counter clockwise to "ON".
- 8) Use the top rocker switch to operate main burner.
- 9) Rotate the variable flame control to adjust the flame height higher or lower.
- 10) Close the bottom louvre assembly.

SHUTDOWN PROCEDURE

- 1) Use the top rocker switch to turn off the main burner.
- 2) Open the bottom louvre assembly.
- 3) Rotate the control knob clockwise to pilot position then push the knob in slightly and continue to rotate to "OFF". Do not force.
- 4) Disconnect all electric power and gas to the appliance if service is to be performed.

FIRST FIRE

The first fire in your stove is part of the curing process. To ensure that the paint is properly cured, light the unit and leave on for 5 minutes and let it cool down for 30 minutes. Repeat 3 or 4 times. When first operated, the unit will release an odour and the flames will appear orange caused by the curing of the paint, the burning off of the starch in the gas logs and the oils on the metal.

The glass panel may require cleaning after the unit has cooled down.

DO NOT ATTEMPT TO CLEAN THE GLASS WHILE IT IS HOT. NEVER OPERATE THE UNIT WITH THE GLASS REMOVED.

CONVECTION FAN OPERATION

The fan operates by using the bottom of the 2 rocker switches on the left-hand side of the fascia. To adjust the desired fan speed, operate the rocker switch. The fan has 2 speeds, a high speed for more rapid air movement and a low speed. The fan should not be used until the unit is up to operating temperature. After the unit has been turned off and the unit cooled down to below a useful heat output range the fan should be shut off.

NOTE: Australian models are fitted with a thermodisc fan control. This means fan will operate only when the heater is up to operating temperature, and will stop automatically once the heater has cooled down. This is particularly useful when a thermostat is fitted, as the fan will not be running unnecessarily. When the thermodisc is fitted, it is not necessary to use the two speed switch on the fascia as it can be kept permanently on at the desired speed setting. The fascia switch overrides the thermodisc if it is set in the "off" position.

NORMAL OPERATING SOUNDS OF GAS APPLIANCES

It is possible that you will hear some sounds from your gas appliance. This is perfectly normal due to the fact that there are various gauges and types of steel used within your appliance. Listed below are some examples, all are **normal operating sounds** and should not be considered as defects in your appliance.

Fan:

Masport gas appliances use high tech blowers to push heated air farther into the room. It is not unusual for the fan to make a "whirring" sound when ON. This sound will increase or decrease in volume depending on the speed setting of your fan.

Burner Tray:

The burner tray is positioned directly under the burner and logs and is made of a different gauge material from the rest of the firebox and body. Therefore, the varying thickness's of steel will expand and contract at slightly different rates, which can cause "ticking" and "cracking" sounds. You should also be aware that as there are temperature changes within the unit these sounds would likely re-occur, again, this is normal for steel fireboxes.

Pilot Flame:

While the pilot flame is on it can make a very slight "whisper" sound.

Gas Control Valve:

As the gas control valve turns ON and OFF, a dull clicking sound may be audible, this is normal operation of a gas regulator or valve.

Unit Body/Firebox:

Different types and thicknesses of steel will expand and contract at different rates resulting in some "cracking" and "ticking" sounds will be heard throughout the cycling process.

GENERAL MAINTENANCE INSTRUCTIONS

- 1) Always turn the gas valve to OFF before cleaning. For relighting, refer to lighting instructions. Keep the burner and control compartment clean by brushing and vacuuming at least once a year. When cleaning the logs, use a clean soft paintbrush, as the logs are fragile and easily damaged.
- 2) Clean (never when unit is hot) appliance, glass and louvers with a damp cloth. Never use an abrasive cleaner. The gold louvers may be scratched if abrasives are used to clean them. The heater is finished in a heat resistant paint and should only be refinished with heat resistant paint (not with wall paint). Masport uses Stove Bright Paint - Metallic Black #6309.
- 3) Keep the area near the appliance clear and free from combustible materials, gasoline and other flammable vapours and liquids.

WARNING: CHILDREN AND ADULTS SHOULD BE ALERTED TO THE HAZARDS OF HIGH SURFACE TEMPERATURE AND SHOULD STAY AWAY TO AVOID BURNS OR CLOTHING IGNITION. YOUNG CHILDREN SHOULD BE CAREFULLY SUPERVISED WHEN THEY ARE IN THE SAME ROOM AS THE APPLIANCE.

CAUTION: ANY SAFETY SCREEN OR GUARD REMOVED FOR SERVICING AN APPLIANCE MUST BE REPLACED PRIOR TO OPERATING THE APPLIANCE. (Australia only)

CLOTHING OR OTHER FLAMMABLE MATERIAL SHOULD NOT BE PLACED ON OR NEAR THE APPLIANCE.

- 4) Each time the appliance is lit, it may cause condensation and fog the glass. This condensation and fog is normal and will disappear in a few minutes as the glass heats up.
Never operate the appliance without the glass properly secured in place or with the door open.
- 5) Periodically check the pilot flames, there should be four strong flames approx. 19 mm long - 1 flame to the front burner, 1 flame to the rear burner, 1 to the thermopile and 1 to the thermocouple.

If you have an incorrect flame pattern, contact your Masport dealer for further instructions.

SERVICING INSTRUCTIONS

(Routine maintenance schedule)

Servicing must be carried out only by authorized personnel.

We recommend that you have your Masport heater checked yearly by an authorized installer. This periodic maintenance should cover the following points:-

- 1) Always turn the gas valve to OFF before cleaning. For relighting, refer to lighting instructions. Keep the burner and control compartment and any air entry points clean by brushing and vacuuming. When cleaning the logs, use a clean soft paintbrush, as the logs are fragile and easily damaged.
- 2) Make a periodic check of burner for proper position and condition. Visually check the flame of the burner periodically, making sure the flames are steady, not lifting or floating. If there is a problem, call an authorized service person.
- 3) The appliance and fluing system must be inspected before use and thereafter annually to ensure that the flow of combustion and ventilation air is not obstructed. During the annual service call, the burners should be removed from the burner tray and cleaned. Replace the embers but do not block the pilot.
- 4) Clean the fan of any lint or foreign matter.
- 5) After the above steps, check the pilot flames, there should be four strong flames approx. 19 mm long - 1 flame to the front burner, 1 flame to the rear burner, 1 to the thermopile and 1 to the thermocouple.
- 6) Check the operation of the thermostat (if fitted) by turning its control point above and below ambient room temperature and checking the response of the fire.

Other points which can be checked after completing the above:-

Thermocouple generation

Gas consumption rate

Carbon dioxide content in the combustion products.

Log Replacement

The unit should never be used with broken logs. Turn off the gas valve and allow the unit to cool before removing the glass to carefully remove the logs. The pilot light generates enough heat to burn someone. If

for any reason a log should need replacement, you must use the proper replacement log. The position of these logs must be as shown in the diagram below.

The rear log is held in place with a screw through the middle of the log. This screw must be tightened just sufficiently to hold the rear of the rear log against the back of the firebox.

The front log assembly is located on 2 pins, one at either end of the front burner.

The top log is positioned on top of both logs and held in place with 2 pieces of wire.

Note: Improper positioning of logs may create carbon build-up and will alter the unit's performance, which is not covered under warranty.

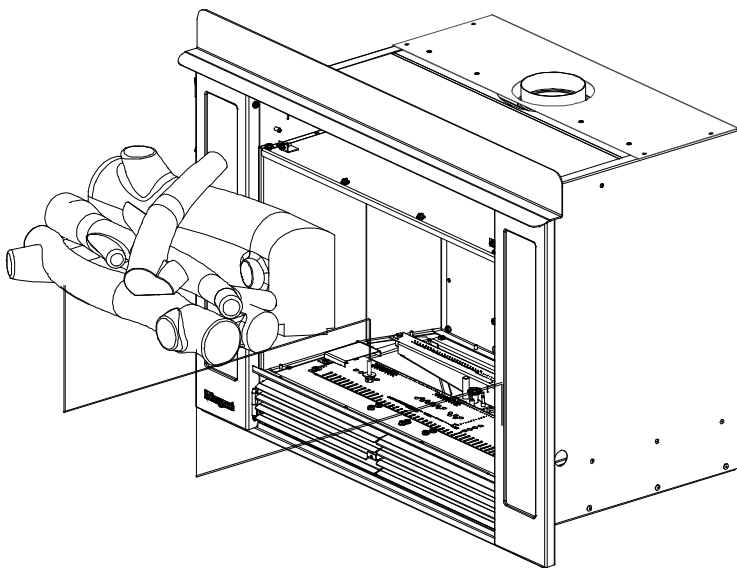

Glass Gasket

If the glass gasket requires replacement use 10mm flat glass gasket for the Bay and Flush Front.

Gold-Plated Trim

The 24-carat gold plated finish on the trim requires little maintenance, and need only be cleaned with a damp cloth. DO NOT use abrasive materials or chemical cleaners, as they may harm the finish and void the warranty. **Clean any fingerprints off before turning the unit on. If the top louvers start to discolour, check the door gasket seal and replace if necessary.**

Door Glass Replacement

Your Masport stove is supplied with high temperature, 5 mm Neoceram ceramic glass that will withstand the highest heat that your unit will produce. In the event that you break your glass by impact, purchase your replacement from an authorized Masport dealer only,

and follow our step-by-step instructions for replacement.

Bay Glass Removal

- 1) Remove the window from the unit (refer to removal instructions on page 10) and place on a soft surface to prevent scratching.
- 2) Remove the nuts holding the glass retainers in place.
- 3) Remove the glass retainers (sides, top and bottom).
- 4) Replace the glass. Install the center and side glass onto the extrusions as per the diagram.

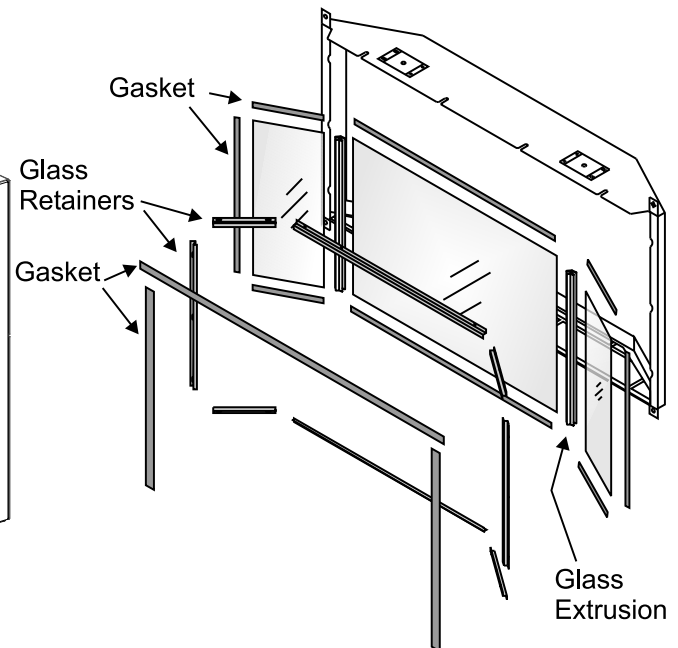

- 5) Reverse the previous steps, replace the retainers and fasten with the nuts but do not over tighten, as this can break the glass.
- 6) Replace window on the fire and check the seal.

Flush Glass Replacement

Flush glass replacement is the same procedure and the Flush front removal/replacement on page 10.

Fan Maintenance

If your fan requires maintenance or replacement, access to the fan is through the plate on the rear wall of the firebox.

Note: The unit MUST NOT be operated without the fan access panel securely in place.

To remove fan:

- 1) Turn the unit and pilot off and allow it to cool to room temperature.
- 2) Unplug or disconnect power source to the fire.
- 3) Remove glass front (see page 10).
- 4) Remove logs (see page 14).
- 5) Loosen the screws securing the rear fan access panel in place. Lift and withdraw the panel passing the keyhole slots over the screw heads.
- 6) Remove the fan deflector just above the fan by removing the 2 screws at either end and lifting it free. Refer to fig on next page.
- 7) Unplug the fan switch lead from the fan stub lead.
- 8) Lift and withdraw the fan assy passing the keyhole slots over the rubber mounting grommits .

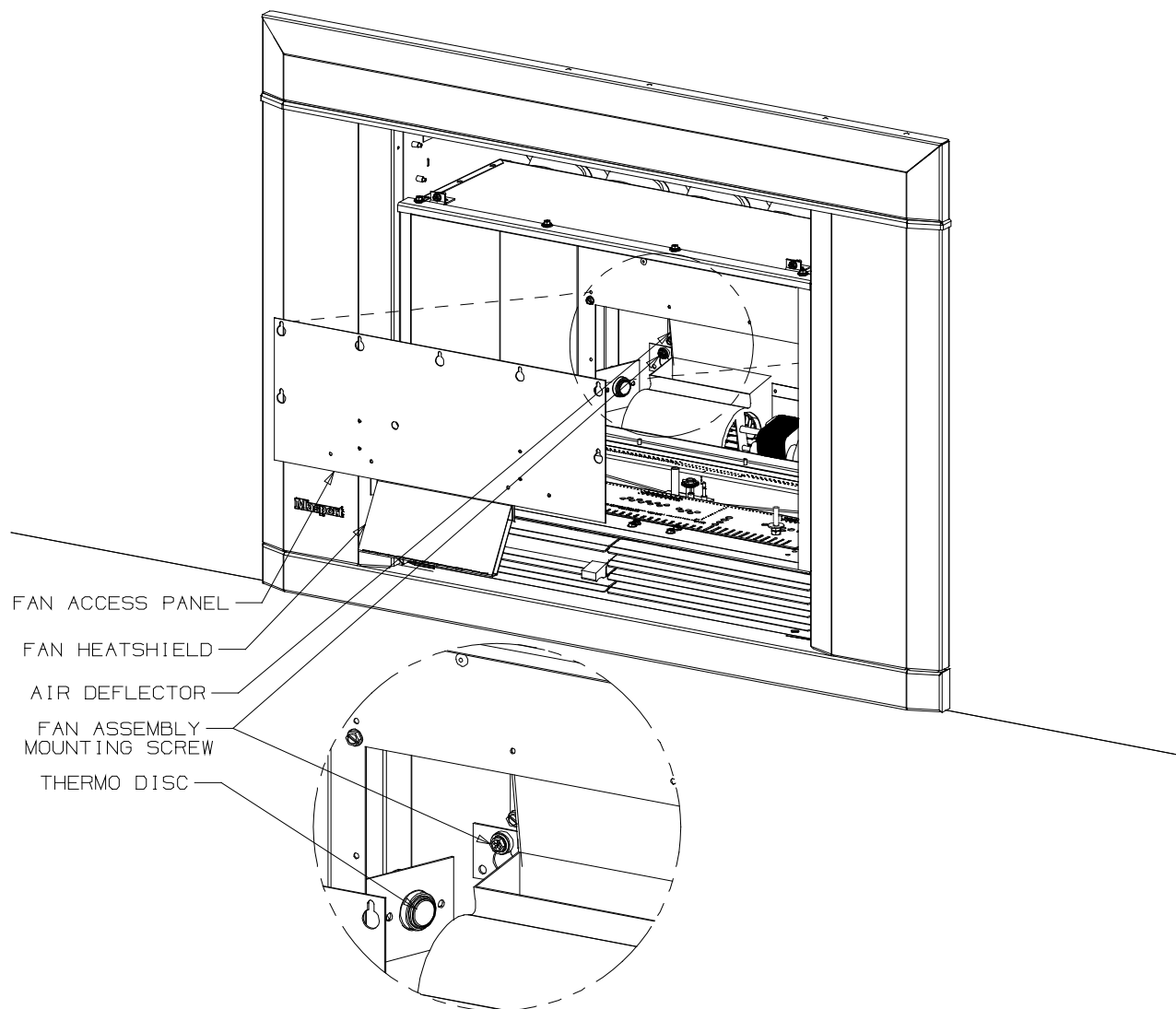

CLEANING INSTRUCTIONS

The outside of the cabinet and glass should need no more than an occasional wipe with a damp cloth to remove any dust which may have settled.

All visible flame gas heaters can produce small amounts of soot, particularly if the combustion air

entry slots under the heater are obstructed or the aeration air inlets are clogged with lint.

After a period of time the inside of the glass may require cleaning. To do this, carefully remove the three glass pieces (See Glass Removal and Assembly, page 10), and clean their inside surfaces with a non-abrasive cloth and a non-scratching type household cleaning liquid.

Replace the parts as detailed on page 10, keeping fingerprints off the inside glass surfaces.
 No other user maintenance should be necessary. If you require any other service or adjustments, contact your Installer or Dealer.

TROUBLE - SHOOTING

The following table lists possible problems and their likely causes. Most of these will require a professional serviceman and we recommend that this work be performed by an Authorized Installer. If a problem cannot be solved after referring to this table, please call your Masport gas fire Dealer for help.

PROBLEM	POSSIBLE CAUSE(S)	SOLUTION
Pilot will not light, and Piezo igniter does not give a strong blue spark.	Faulty electrode wire connection(s).	Make sure connections are firm.
Pilot will not light even Though the piezo igniter produces a strong blue spark.	Incorrect lighting procedure.	Follow the instructions in this manual.
	No gas supply at heater.	Check for closed gas valve(s) or faulty gas supply lines.
	Pilot filter or jet blocked.	Replace filter in control valve - clean jet.
	No fuel in LPG system.	Replenish LPG supply.
Pilot stays alight but main Burner will not light.	Thermostat (if fitted) is switched to OFF or set to a low temperature.	Check thermostat setting. Switch to ON or turn to a higher temperature.
	Thermostat defective, or thermostat wiring to heater is faulty.	If wiring is undamaged and the connections are sound at each end, thermostat may need replacing.
Smell of flue gas in the room.	Flue gas spilling from the draught diverter at the rear of the heater.	Check for flue blockage, negative air pressure in the room or circumstances causing down draught.
Smell of gas in the room.	Pipe fittings may be leaking.	Check all joints for leaks, including the gas supply system, the pilot light supply tube, the main burner supply tube and all connections to the control valve and pressure reducing valve (NG models). Use ONLY a proper leak check solution. NEVER USE AN OPEN FLAME TO CHECK FOR LEAKS

PROBLEM	POSSIBLE CAUSE(S)	SOLUTION
A thin coating of black soot forms inside the glass.	Combustion air supply restricted. Over-supply of gas. Logs out of position.	Clean all primary and secondary air passageways. Adjust gas delivery pressure at test point. Arrange logs correctly.
A white coating forms inside the glass.	Residues in new logs being Follow glass cleaning burned off.	Follow glass cleaning directions under Cleaning Instructions.
Fan hums but there is poor air circulation.	Dirty fan impeller	Disconnect electrical power. Remove and clean fan impeller.
Fan will not run.	No power to fan.	Make sure fan plug is firmly home and that fan switch is not in the OFF position. Check that the power socket works with another appliance.

